

**SECTION EI**  
**EXTERIOR & INTERIOR**

A  
B  
C  
D  
E  
F  
G  
H  
EI  
J  
K  
L  
M

**CONTENTS**

<b>PRECAUTIONS</b> .....	<b>3</b>	<b>FRONT GRILLE</b> .....	<b>19</b>
Precautions for Supplemental Restraint System (SRS) "AIR BAG" and "SEAT BELT PRE-TENSIONER" .....	3	Removal and Installation .....	19
Precautions for Battery Service .....	3	REMOVAL .....	19
Precautions for Work .....	3	INSTALLATION .....	19
<b>PREPARATION</b> .....	<b>4</b>	<b>COWL TOP</b> .....	<b>20</b>
Special Service Tools .....	4	Removal and Installation .....	20
Commercial Service Tool .....	4	REMOVAL .....	20
<b>SQUEAK AND RATTLE TROUBLE DIAGNOSES</b> .....	<b>5</b>	INSTALLATION .....	20
Work Flow .....	5	<b>FENDER PROTECTOR</b> .....	<b>21</b>
CUSTOMER INTERVIEW .....	5	Removal and Installation .....	21
DUPLICATE THE NOISE AND TEST DRIVE .....	6	RE MOVAL .....	21
CHECK RELATED SERVICE BULLETINS .....	6	INSTALLATION .....	21
LOCATE THE NOISE AND IDENTIFY THE ROOT CAUSE .....	6	<b>DOOR OUTSIDE MOLDING</b> .....	<b>22</b>
REPAIR THE CAUSE .....	6	Removal and Installation .....	22
CONFIRM THE REPAIR .....	7	REMOVAL .....	22
Generic Squeak and Rattle Troubleshooting .....	7	INSTALLATION .....	22
INSTRUMENT PANEL .....	7	<b>FRONT PILLAR FINISHER</b> .....	<b>23</b>
CENTER CONSOLE .....	7	Removal and Installation .....	23
DOORS .....	7	REMOVAL .....	23
TRUNK .....	8	INSTALLATION .....	23
SUNROOF/HEADLINING .....	8	<b>CENTER MUD GUARD</b> .....	<b>24</b>
SEATS .....	8	Removal and Installation .....	24
UNDERHOOD .....	8	REMOVAL .....	24
Diagnostic Worksheet .....	9	INSTALLATION .....	24
<b>CLIP AND FASTENER</b> .....	<b>11</b>	<b>WINDSHIELD MOLDING</b> .....	<b>25</b>
Clip and Fastener .....	11	Removal and Installation .....	25
<b>FRONT BUMPER</b> .....	<b>14</b>	REMOVAL .....	25
Removal and Installation .....	14	INSTALLATION .....	25
REMOVAL .....	16	<b>REAR WINDOW MOLDING</b> .....	<b>27</b>
INSTALLATION .....	16	Removal and Installation .....	27
<b>REAR BUMPER</b> .....	<b>17</b>	REMOVAL .....	27
Removal and Installation .....	17	INSTALLATION .....	27
REMOVAL .....	17	<b>REAR SPOILER</b> .....	<b>28</b>
INSTALLATION .....	18	Removal and Installation .....	28
		REMOVAL .....	28
		INSTALLATION .....	28
		<b>ROOF SIDE MOLDING</b> .....	<b>29</b>
		Removal and Installation .....	29
		REMOVAL .....	29
		INSTALLATION .....	29

<b>DOOR FINISHER .....</b>	<b>30</b>	<b>FLOOR TRIM .....</b>	<b>36</b>
Removal and Installation .....	30	Removal and Installation .....	36
REMOVAL .....	30	REMOVAL .....	36
INSTALLATION .....	31	INSTALLATION .....	37
<b>BODY SIDE TRIM .....</b>	<b>32</b>	<b>HEADLINING .....</b>	<b>38</b>
Removal and Installation .....	32	Removal and Installation .....	38
REAR SIDE FINISHER .....	32	REMOVAL .....	39
REAR PILLAR GARNISH .....	33	INSTALLATION .....	39
FRONT PILLAR GARNISH .....	33	<b>TRUNK ROOM TRIM &amp; TRUNK LID FINISHER .....</b>	<b>40</b>
KICKING PLATE .....	33	Removal and Installation for Trunk Room Trim .....	40
CENTER MUD GUARD FINISHER .....	33	TRUNK ROOM TRIM .....	40
DASH SIDE FINISHER .....	33	TRUNK LID FINISHER .....	41
<b>REAR PARCEL SHELF FINISHER .....</b>	<b>35</b>		
Removal and Installation .....	35		
REMOVAL .....	35		
INSTALLATION .....	35		

# PRECAUTIONS

## PRECAUTIONS

PF0:00001

### Precautions for Supplemental Restraint System (SRS) “AIR BAG” and “SEAT BELT PRE-TENSIONER”

AIS001AW

The Supplemental Restraint System such as “AIR BAG” and “SEAT BELT PRE-TENSIONER”, used along with a front seat belt, helps to reduce the risk or severity of injury to the driver and front passenger for certain types of collision. This system includes seat belt switch inputs and dual stage front air bag modules. The SRS system uses the seat belt switches to determine the front air bag deployment, and may only deploy one front air bag, depending on the severity of a collision and whether the front occupants are belted or unbelted. Information necessary to service the system safely is included in the SRS and SB section of this Service Manual.

#### **WARNING:**

- To avoid rendering the SRS inoperative, which could increase the risk of personal injury or death in the event of a collision which would result in air bag inflation, all maintenance must be performed by an authorized NISSAN/INFINITI dealer.
- Improper maintenance, including incorrect removal and installation of the SRS, can lead to personal injury caused by unintentional activation of the system. For removal of Spiral Cable and Air Bag Module, see the SRS section.
- Do not use electrical test equipment on any circuit related to the SRS unless instructed to in this Service Manual. SRS wiring harnesses can be identified by yellow and/or orange harnesses or harness connectors.

### Precautions for Battery Service

AIS002MP

Before disconnecting the battery, lower both the driver and passenger windows. This will prevent any interference between the window edge and the vehicle when the door is opened/closed. During normal operation, the window slightly raises and lowers automatically to prevent any window to vehicle interference. The automatic window function will not work with the battery disconnected.

### Precautions for Work

AIS001AX

- After removing and installing the opening/closing parts, be sure to carry out fitting adjustments to check their operation.
- Check the lubrication level, damage, and wear of each part. If necessary, grease or replace it.

A

B

C

D

E

F

G

H

EI

J

K

L

M

# PREPARATION

## PREPARATION

PFP:00002

### Special Service Tools

AIS004Y5

The actual shapes of Kent-Moore tools may differ from those of special service tools illustrated here.

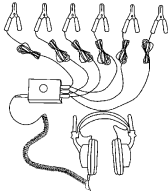
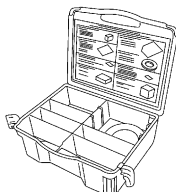
Tool number (Kent-Moore No.) Tool name	Description
(J-39570) Chassis ear   <p style="text-align: right; margin-right: 20px;">SIIA0993E</p>	Locating the noise
(J-43980) NISSAN Squeak and Rattle Kit   <p style="text-align: right; margin-right: 20px;">SIIA0994E</p>	Repairing the cause of noise

### Commercial Service Tool

AIS004Y6

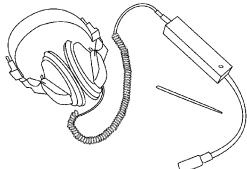
Tool name	Description
Engine ear   <p style="text-align: right; margin-right: 20px;">SIIA0995E</p>	Locating the noise

# SQUEAK AND RATTLE TROUBLE DIAGNOSES

## SQUEAK AND RATTLE TROUBLE DIAGNOSES

PPF:00000

### Work Flow

AIS004Y7

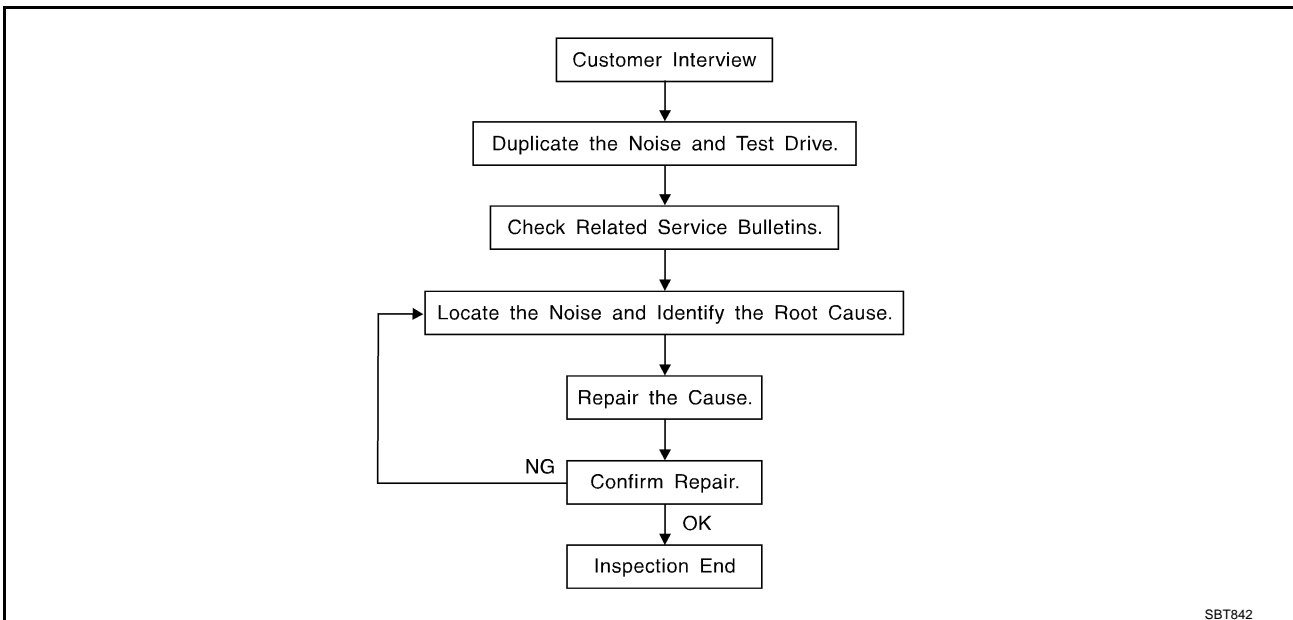

### CUSTOMER INTERVIEW

Interview the customer if possible, to determine the conditions that exist when the noise occurs. Use the Diagnostic Worksheet during the interview to document the facts and conditions when the noise occurs and any customer's comments; refer to [EI-9, "Diagnostic Worksheet"](#). This information is necessary to duplicate the conditions that exist when the noise occurs.

- The customer may not be able to provide a detailed description or the location of the noise. Attempt to obtain all the facts and conditions that exist when the noise occurs (or does not occur).
- If there is more than one noise in the vehicle, be sure to diagnose and repair the noise that the customer is concerned about. This can be accomplished by test driving the vehicle with the customer.
- After identifying the type of noise, isolate the noise in terms of its characteristics. The noise characteristics are provided so the customer, service adviser and technician are all speaking the same language when defining the noise.
- Squeak—(Like tennis shoes on a clean floor)  
Squeak characteristics include the light contact/fast movement/brought on by road conditions/hard surfaces=higher pitch noise/softer surfaces=lower pitch noises/edge to surface=chirping
- Creak—(Like walking on an old wooden floor)  
Creak characteristics include firm contact/slow movement/twisting with a rotational movement/pitch dependent on materials/often brought on by activity.
- Rattle—(Like shaking a baby rattle)  
Rattle characteristics include the fast repeated contact/vibration or similar movement/loose parts/missing clip or fastener/incorrect clearance.
- Knock—(Like a knock on a door)  
Knock characteristics include hollow sounding/sometimes repeating/often brought on by driver action.
- Tick—(Like a clock second hand)  
Tick characteristics include gentle contacting of light materials/loose components/can be caused by driver action or road conditions.
- Thump—(Heavy, muffled knock noise)  
Thump characteristics include softer knock/dead sound often brought on by activity.
- Buzz—(Like a bumble bee)  
Buzz characteristics include high frequency rattle/firm contact.
- Often the degree of acceptable noise level will vary depending upon the person. A noise that you may judge as acceptable may be very irritating to the customer.
- Weather conditions, especially humidity and temperature, may have a great effect on noise level.

# SQUEAK AND RATTLE TROUBLE DIAGNOSES

## DUPLICATE THE NOISE AND TEST DRIVE

If possible, drive the vehicle with the customer until the noise is duplicated. Note any additional information on the Diagnostic Worksheet regarding the conditions or location of the noise. This information can be used to duplicate the same conditions when you confirm the repair.

If the noise can be duplicated easily during the test drive, to help identify the source of the noise, try to duplicate the noise with the vehicle stopped by doing one or all of the following:

- 1) Close a door.
  - 2) Tap or push/pull around the area where the noise appears to be coming from.
  - 3) Rev the engine.
  - 4) Use a floor jack to recreate vehicle "twist".
  - 5) At idle, apply engine load (electrical load, half-clutch on M/T model, drive position on A/T model).
  - 6) Raise the vehicle on a hoist and hit a tire with a rubber hammer.
- Drive the vehicle and attempt to duplicate the conditions the customer states exist when the noise occurs.
  - If it is difficult to duplicate the noise, drive the vehicle slowly on an undulating or rough road to stress the vehicle body.

## CHECK RELATED SERVICE BULLETINS

After verifying the customer concern or symptom, check ASIST for Technical Service Bulletins (TSBs) related to that concern or symptom.

If a TSB relates to the symptom, follow the procedure to repair the noise.

## LOCATE THE NOISE AND IDENTIFY THE ROOT CAUSE

1. Narrow down the noise to a general area. To help pinpoint the source of the noise, use a listening tool (Chassis Ear: J-39570, Engine Ear and mechanics stethoscope).
2. Narrow down the noise to a more specific area and identify the cause of the noise by:
  - removing the components in the area that you suspect the noise is coming from.  
Do not use too much force when removing clips and fasteners, otherwise clips and fastener can be broken or lost during the repair, resulting in the creation of new noise.
  - tapping or pushing/pulling the component that you suspect is causing the noise.  
Do not tap or push/pull the component with excessive force, otherwise the noise will be eliminated only temporarily.
  - feeling for a vibration with your hand by touching the component(s) that you suspect is (are) causing the noise.
  - placing a piece of paper between components that you suspect are causing the noise.
  - looking for loose components and contact marks.  
Refer to [EI-7, "Generic Squeak and Rattle Troubleshooting"](#).

## REPAIR THE CAUSE

- If the cause is a loose component, tighten the component securely.
- If the cause is insufficient clearance between components:
  - separate components by repositioning or loosening and retightening the component, if possible.
  - insulate components with a suitable insulator such as urethane pads, foam blocks, felt cloth tape or urethane tape. A Nissan Squeak and Rattle Kit (J-43980) is available through your authorized Nissan Parts Department.

### CAUTION:

**Do not use excessive force as many components are constructed of plastic and may be damaged.**

**Always check with the Parts Department for the latest parts information.**

**The following materials are contained in the Nissan Squeak and Rattle Kit (J-43980). Each item can be ordered separately as needed.**

**URETHANE PADS [1.5 mm (0.059 in) thick]**

**Insulates connectors, harness, etc.**

**76268-9E005: 100 × 135 mm (3.94 × 5.31 in)/76884-71L01: 60 × 85 mm (2.36 × 3.35 in)/76884-71L02: 15 × 25 mm (0.59 × 0.98 in)**

**INSULATOR (Foam blocks)**

**Insulates components from contact. Can be used to fill space behind a panel.**

**73982-9E000: 45 mm (1.77 in) thick, 50 × 50 mm (1.97 × 1.97 in)/73982-50Y00: 10 mm (0.39 in) thick, 50 × 50 mm (1.97 × 1.97 in)**

# SQUEAK AND RATTLE TROUBLE DIAGNOSES

## INSULATOR (Light foam block)

80845-71L00: 30 mm (1.18 in) thick, 30 × 50 mm (1.18 × 1.97 in)

## FELT CLOTHTAPE

Used to insulate where movement does not occur. Ideal for instrument panel applications.

68370-4B000: 15 × 25 mm (0.59 × 0.98 in) pad/68239-13E00:5 mm (0.20 in) wide tape roll

The following materials, not found in the kit, can also be used to repair squeaks and rattles.

## UHMW(TEFLON) TAPE

Insulates where slight movement is present. Ideal for instrument panel applications.

## SILICONE GREASE

Used in place of UHMW tape that will be visible or not fit.

Note: Will only last a few months.

## SILICONE SPRAY

Use when grease cannot be applied.

## DUCT TAPE

Use to eliminate movement.

## CONFIRM THE REPAIR

Confirm that the cause of a noise is repaired by test driving the vehicle. Operate the vehicle under the same conditions as when the noise originally occurred. Refer to the notes on the Diagnostic Worksheet.

## Generic Squeak and Rattle Troubleshooting

AIS004Y8

Refer to Table of Contents for specific component removal and installation information.

## INSTRUMENT PANEL

Most incidents are caused by contact and movement between:

1. The cluster lid A and instrument panel
2. Acrylic lens and combination meter housing
3. Instrument panel to front pillar garnish
4. Instrument panel to windshield
5. Instrument panel mounting pins
6. Wiring harnesses behind the combination meter
7. A/C defroster duct and duct joint

These incidents can usually be located by tapping or moving the components to duplicate the noise or by pressing on the components while driving to stop the noise. Most of these incidents can be repaired by applying felt cloth tape or silicon spray (in hard to reach areas). Urethane pads can be used to insulate wiring harness.

### CAUTION:

**Do not use silicone spray to isolate a squeak or rattle. If you saturate the area with silicone, you will not be able to recheck the repair.**

## CENTER CONSOLE

Components to pay attention to include:

1. Shifter assembly cover to finisher
2. A/C control unit and cluster lid C
3. Wiring harnesses behind audio and A/C control unit

The instrument panel repair and isolation procedures also apply to the center console.

## DOORS

Pay attention to the:

1. Finisher and inner panel making a slapping noise
2. Inside handle escutcheon to door finisher
3. Wiring harnesses tapping
4. Door striker out of alignment causing a popping noise on starts and stops

Tapping or moving the components or pressing on them while driving to duplicate the conditions can isolate many of these incidents. You can usually insulate the areas with felt cloth tape or insulator foam blocks from the Nissan Squeak and Rattle Kit (J-43980) to repair the noise.

# SQUEAK AND RATTLE TROUBLE DIAGNOSES

---

## TRUNK

Trunk noises are often caused by a loose jack or loose items put into the trunk by the owner. In addition look for:

1. Trunk lid dumpers out of adjustment
2. Trunk lid striker out of adjustment
3. The trunk lid torsion bars knocking together
4. A loose license plate or bracket

Most of these incidents can be repaired by adjusting, securing or insulating the item(s) or component(s) causing the noise.

## SUNROOF/HEADLINING

Noises in the sunroof/headlining area can often be traced to one of the following:

1. Sunroof lid, rail, linkage or seals making a rattle or light knocking noise
2. Sunvisor shaft shaking in the holder
3. Front or rear windshield touching headlining and squeaking

Again, pressing on the components to stop the noise while duplicating the conditions can isolate most of these incidents. Repairs usually consist of insulating with felt cloth tape.

## SEATS

When isolating seat noise it's important to note the position the seat is in and the load placed on the seat when the noise is present. These conditions should be duplicated when verifying and isolating the cause of the noise.

Cause of seat noise include:

1. Headrest rods and holder
2. A squeak between the seat pad cushion and frame
3. The rear seatback lock and bracket

These noises can be isolated by moving or pressing on the suspected components while duplicating the conditions under which the noise occurs. Most of these incidents can be repaired by repositioning the component or applying urethane tape to the contact area.

## UNDERHOOD

Some interior noise may be caused by components under the hood or on the engine wall. The noise is then transmitted into the passenger compartment.

Causes of transmitted underhood noise include:

1. Any component mounted to the engine wall
2. Components that pass through the engine wall
3. Engine wall mounts and connectors
4. Loose radiator mounting pins
5. Hood bumpers out of adjustment
6. Hood striker out of adjustment

These noises can be difficult to isolate since they cannot be reached from the interior of the vehicle. The best method is to secure, move or insulate one component at a time and test drive the vehicle. Also, engine RPM or load can be changed to isolate the noise. Repairs can usually be made by moving, adjusting, securing, or insulating the component causing the noise.



# SQUEAK AND RATTLE TROUBLE DIAGNOSES

## Diagnostic Worksheet

AIS004Y9



### SQUEAK & RATTLE DIAGNOSTIC WORKSHEET

Dear Infiniti Customer:

We are concerned about your satisfaction with your Infiniti vehicle. Repairing a squeak or rattle sometimes can be very difficult. To help us fix your Infiniti right the first time, please take a moment to note the area of the vehicle where the squeak or rattle occurs and under what conditions. You may be asked to take a test drive with a service advisor or technician to ensure we confirm the noise you are hearing.

#### I. WHERE DOES THE NOISE COME FROM? (circle the area of the vehicle)

The illustrations are for reference only, and may not reflect the actual configuration of your vehicle.

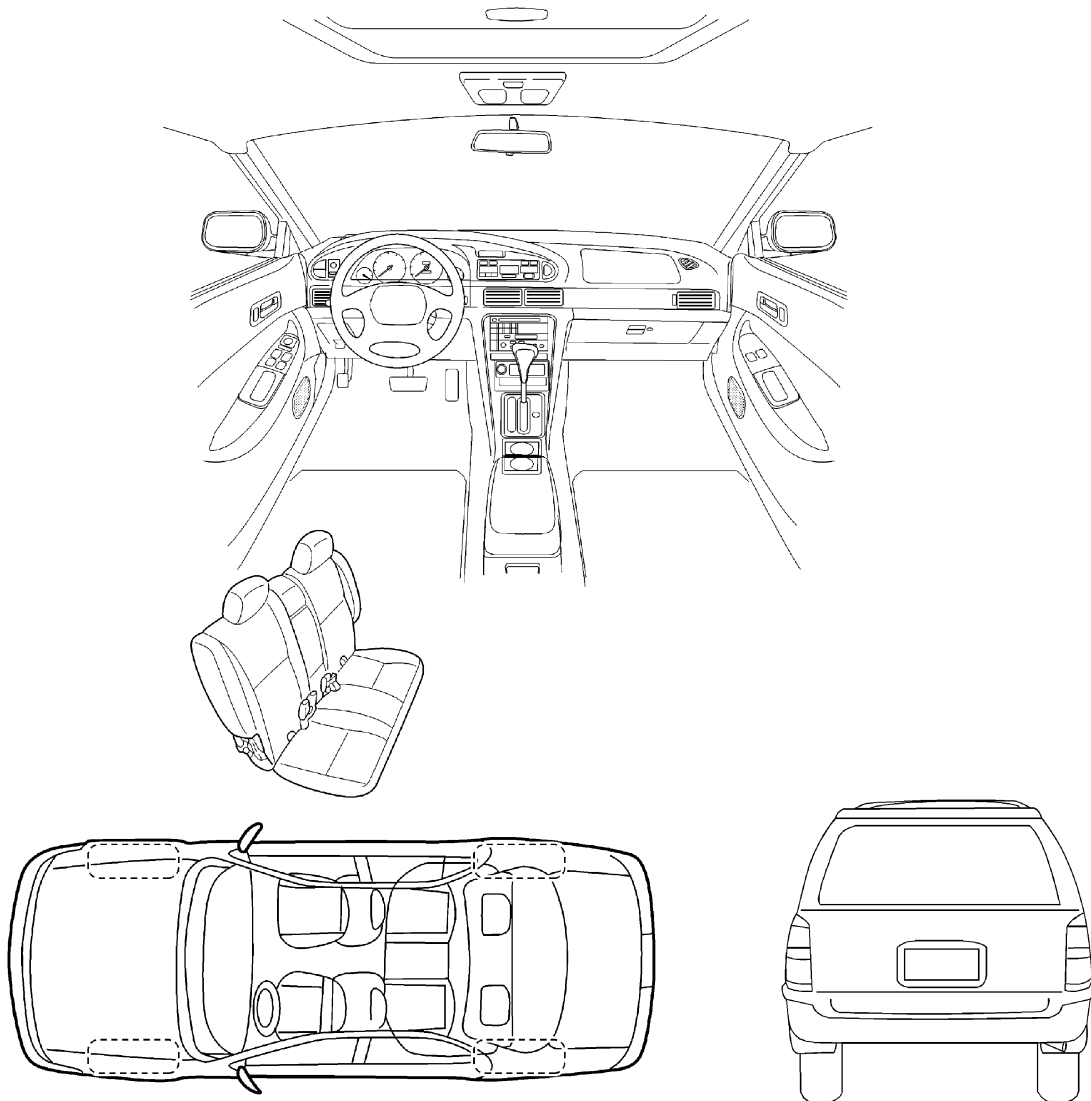

Continue to the back of the worksheet and briefly describe the location of the noise or rattle. In addition, please indicate the conditions which are present when the noise occurs.

SBT860

A  
B  
C  
D  
E  
F  
G  
H  
EI  
J  
K  
L  
M

# SQUEAK AND RATTLE TROUBLE DIAGNOSES

## SQUEAK & RATTLE DIAGNOSTIC WORKSHEET- page 2

Briefly describe the location where the noise occurs:

---

---

---

### II. WHEN DOES IT OCCUR? (check the boxes that apply)

- |  |   |
|--|---|
| <input type="checkbox"/> anytime                             | <input type="checkbox"/> after sitting out in the sun |
| <input type="checkbox"/> 1 <sup>st</sup> time in the morning | <input type="checkbox"/> when it is raining or wet    |
| <input type="checkbox"/> only when it is cold outside        | <input type="checkbox"/> dry or dusty conditions      |
| <input type="checkbox"/> only when it is hot outside         | <input type="checkbox"/> other: _____                 |

### III. WHEN DRIVING:

- through driveways
- over rough roads
- over speed bumps
- only at about \_\_\_\_ mph
- on acceleration
- coming to a stop
- on turns : left, right or either (circle)
- with passengers or cargo
- other: \_\_\_\_\_
- after driving \_\_\_\_ miles or \_\_\_\_ minutes

### IV. WHAT TYPE OF NOISE?

- squeak (like tennis shoes on a clean floor)
- creak (like walking on an old wooden floor)
- rattle (like shaking a baby rattle)
- knock (like a knock on a door)
- tick (like a clock second hand)
- thump (heavy, muffled knock noise)
- buzz (like a bumble bee)

### TO BE COMPLETED BY DEALERSHIP PERSONNEL

#### Test Drive Notes:

---

---

	YES	NO	Initials of person performing
Vehicle test driven with customer	<input type="checkbox"/>	<input type="checkbox"/>	_____
- Noise verified on test drive	<input type="checkbox"/>	<input type="checkbox"/>	_____
- Noise source located and repaired	<input type="checkbox"/>	<input type="checkbox"/>	_____
- Follow up test drive performed to confirm repair	<input type="checkbox"/>	<input type="checkbox"/>	_____

VIN: \_\_\_\_\_ Customer Name: \_\_\_\_\_

W.O. #: \_\_\_\_\_ Date: \_\_\_\_\_

**This form must be attached to Work Order**







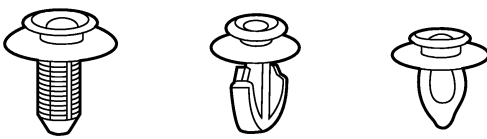
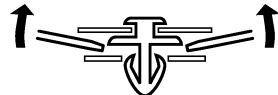

# CLIP AND FASTENER

## CLIP AND FASTENER

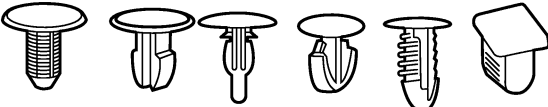
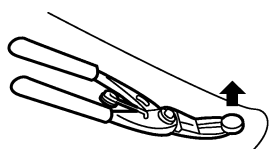
PFP:76906

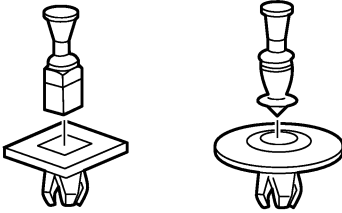
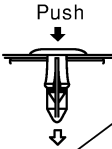
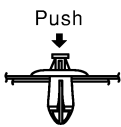
### Clip and Fastener

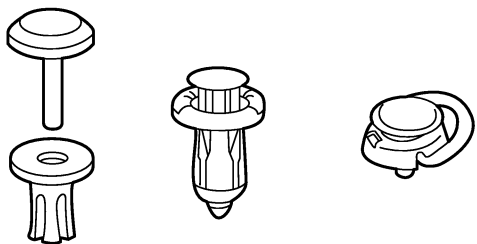

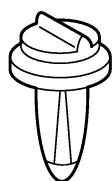
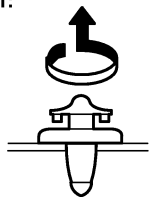





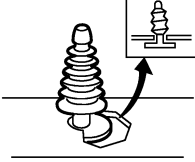
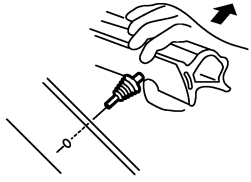

AIS001B4

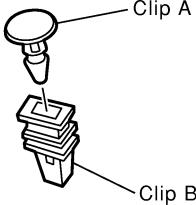
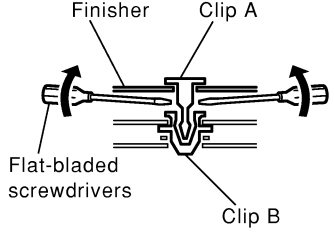
Symbol No.	Shapes	Removal & Installation
<p>C101</p> 		<p><b>Removal:</b> Remove by bending up with flat-bladed screwdrivers or clip remover.</p> 
<p>C103</p> 		 <p><b>Removal:</b> Remove with a clip remover.</p>
<p>C203</p> 		<p><b>Removal:</b> Push center pin to catching position. (Do not remove center pin by hitting it.)</p>  <p><b>Installation:</b></p> 
<p>C205</p> 		<p><b>Removal:</b> Flat-bladed screwdriver</p>  <p>Clip Finisher</p>
<p>C206</p> 		<p><b>Removal:</b></p> 

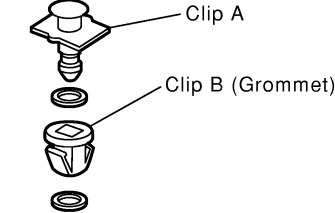
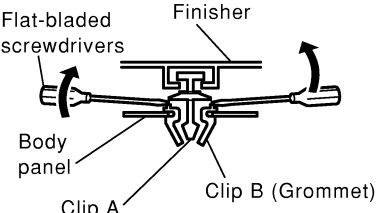

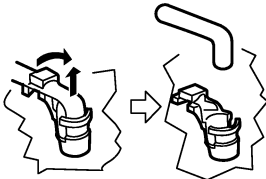

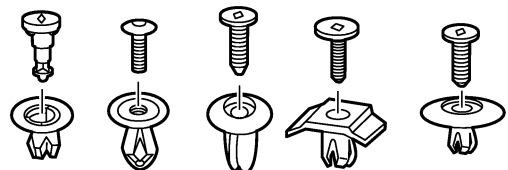





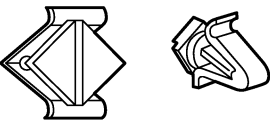

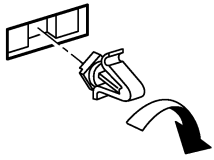
A  
B  
C  
D  
E  
F  
G  
H  
I  
J  
K  
L  
M

EI

# CLIP AND FASTENER

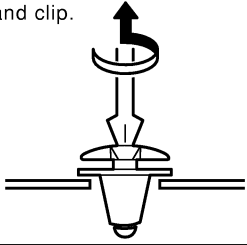
Symbol No.	Shapes	Removal & Installation
<p>CE103</p> 		<p><b>Removal:</b></p> 
<p>CF110</p> 		<p><b>Removal:</b></p> 
<p>CF118</p> 		<p><b>Removal:</b></p> 
<p>CR103</p> 		<p><b>Removal:</b> Holder portion of clip must be spread out to remove rod.</p> 
<p>CS101</p> 		<p><b>Removal:</b></p> <ol style="list-style-type: none"> <li>1. Screw out with a Phillips screwdriver.</li> <li>2. Remove female portion with flat-bladed screwdriver.</li> </ol> 

# CLIP AND FASTENER

Symbol No.	Shapes	Removal & Installation	
<p>CG101</p> 		<p><b>Removal:</b></p>  <p>Rotate 45° to remove</p>	<p><b>Installation:</b></p> 
<p>CS102</p> 			
<p>CS113</p> 		<p><b>Removal:</b> Disconnect upper connection of clip with a flat-bladed screwdriver, then remove clip while inserting a flat-bladed screwdriver between body panel and clip.</p> 	
<p>C111</p> 			

A  
B  
C  
D  
E  
F  
G  
H  
EI  
J  
K  
L  
M

# FRONT BUMPER

---

## FRONT BUMPER

PFP:F2022

### Removal and Installation

AIS004YA

**CAUTION:**

Bumper fascia is made of resin. Do not apply strong force to it, and be careful to prevent contact with oil.

# FRONT BUMPER

SEC. 620

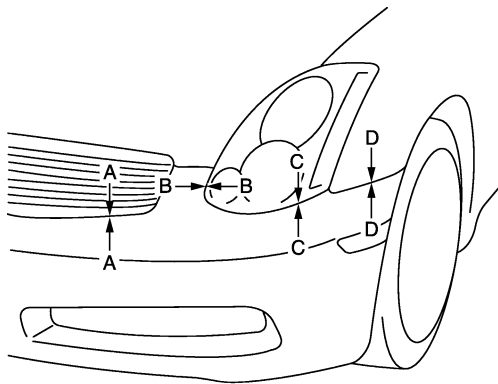
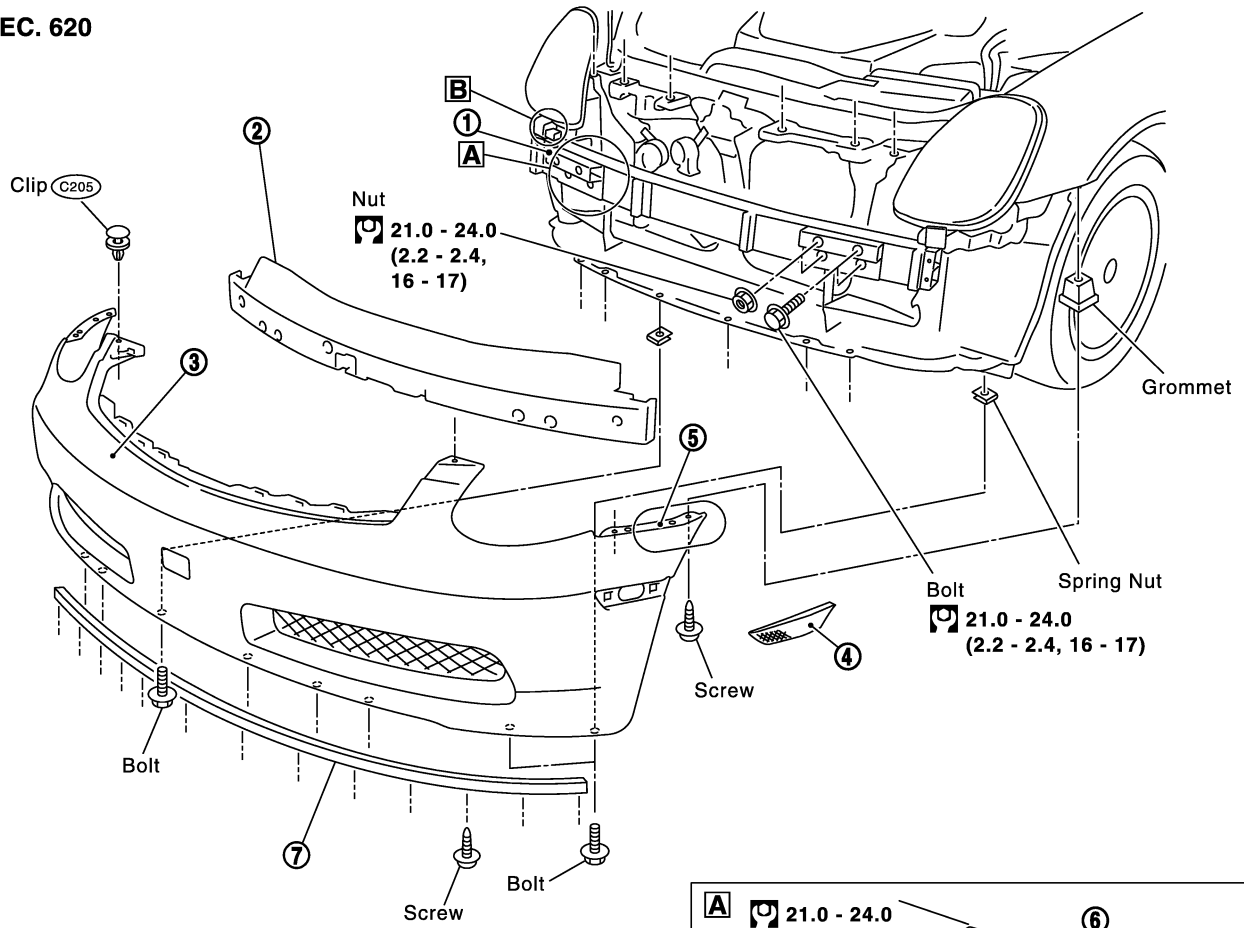

Clearance measurement  
between parts  
A - A: 0.5 - 3.5 (0.020 - 0.138)  
B - B: 2.5 - 5.5 (0.098 - 0.217)  
C - C: 1.5 - 4.5 (0.059 - 0.177)  
D - D: 0 - 1.5 (0 - 0.059)  
Unit: mm (in)

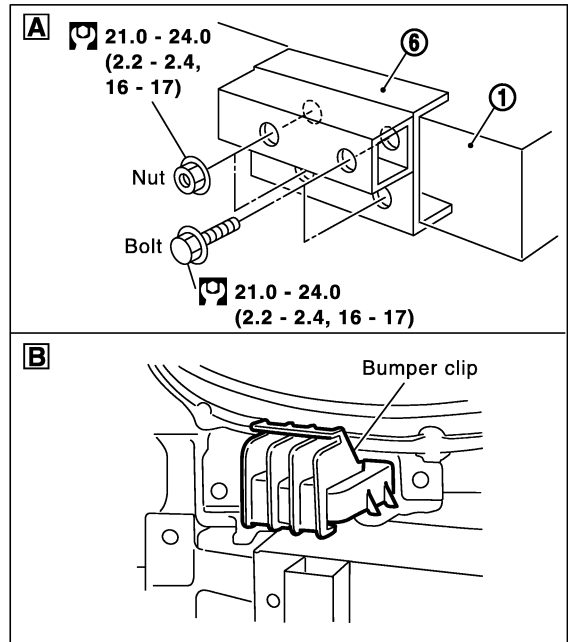

: N•m (kg-m, ft-lb)

PIIA3563E

A  
B  
C  
D  
E  
F  
G  
H  
EI  
J  
K  
L  
M

# FRONT BUMPER

---

- |                          |                        |                           |
|--------------------------|------------------------|---------------------------|
| 1. Bumper reinforcement  | 2. Energy absorber     | 3. Bumper fascia assembly |
| 4. Side turn signal lamp | 5. Bumper side bracket | 6. Bumper over rider      |
| 7. Front air spoiler     |                        |                           |

## REMOVAL

1. Remove bumper clips, front grille clips, and remove front grille. Refer to [EI-19, "FRONT GRILLE"](#) .
2. Remove screws of front air spoiler and remove front air spoiler.
3. Remove bolts on lower side of bumper.
4. Remove screws and clips of both right/left fender protectors on front side. Refer to [EI-21, "FENDER PROTECTOR"](#) .
5. Remove screws of both right/left fender.
6. Disconnect turn signal lamp harness connector.
7. Remove bumper fascia assembly.
8. Remove energy absorber.
9. Remove bolts and nuts of bumper reinforcement and remove bumper reinforcement.
10. Remove bolts of bumper bracket and remove bumper bracket.
11. Remove side turn signal lamps located in bumper fascia. Refer to [LT-122, "Removal and Installation of Front Turn Signal Lamp"](#) .

## INSTALLATION

Install in the reverse order of removal.



# REAR BUMPER

PFP:H5022

AI5004YB

## REAR BUMPER

### Removal and Installation

#### CAUTION:

Bumper fascia is made of resin. Do not apply strong force to it, and be careful to prevent contact with oil.

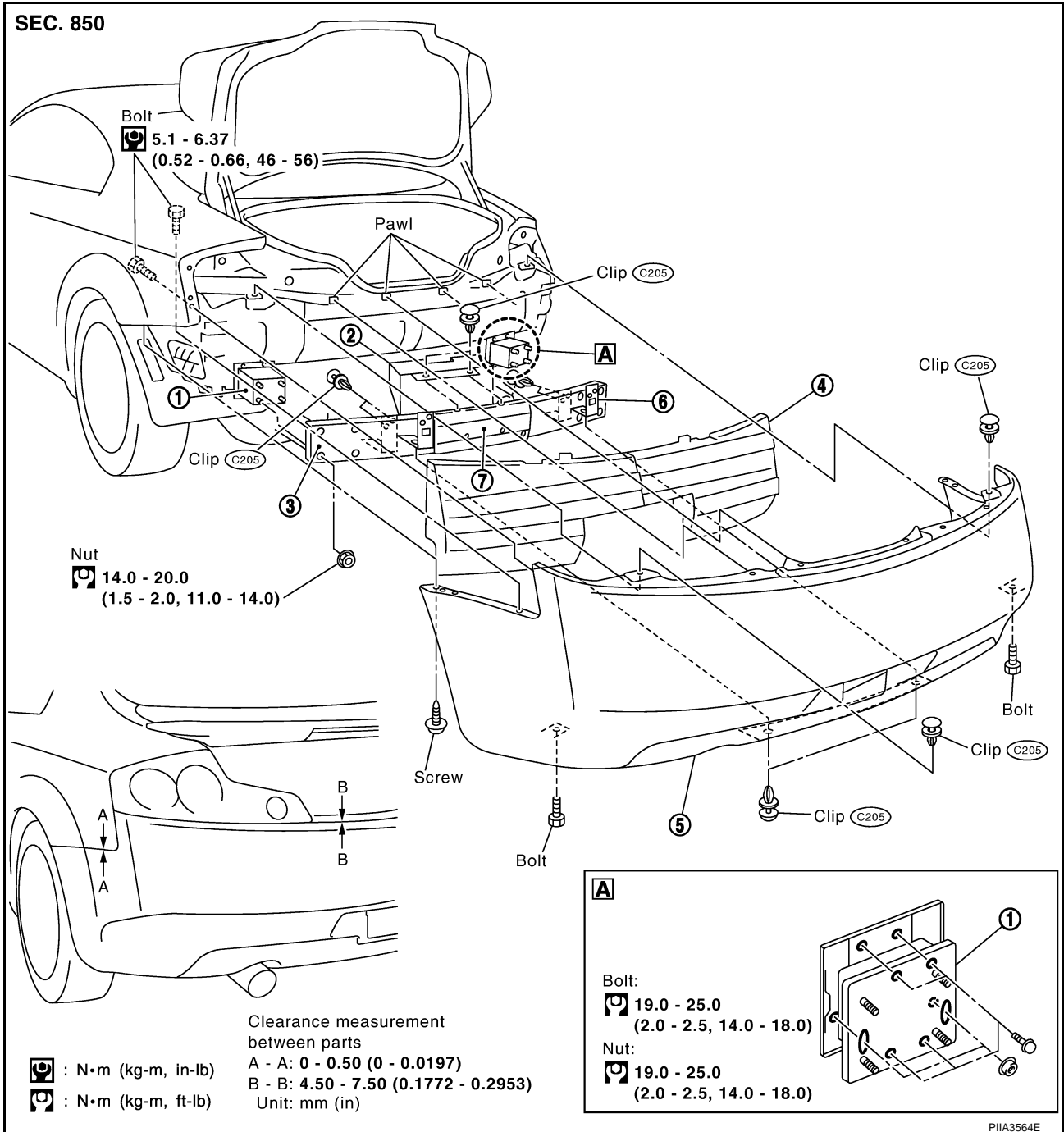

- |                            |                           |                            |
|----------------------------|---------------------------|----------------------------|
| 1. Bumper stay             | 2. Energy absorber (rear) | 3. Bumper reinforcement    |
| 4. Energy absorber (front) | 5. Bumper fascia assembly | 6. Bumper retainer (lower) |
| 7. Bumper overrider        |                           |                            |

#### REMOVAL

1. Remove trunk trim. Refer to [EI-40, "TRUNK ROOM TRIM & TRUNK LID FINISHER"](#) .
2. Remove rear combination lamp assembly. Refer to [LT-155, "Removal and Installation"](#) .
3. Remove bumper fascia bolts from both right/left rear fender.

## REAR BUMPER

---

4. Remove bumper fascia clips of upper portion, and remove screw of lower portion.
5. Pull out center of bumper fascia, and remove bumper fascia from clips.
6. Disconnect license lamp harness connector and remove bumper fascia assembly.
7. Remove energy absorber (front).
8. Remove reinforcement assembly nuts.

### **INSTALLATION**

Install in the reverse order of removal.

# FRONT GRILLE

## FRONT GRILLE

PFP:62310

### Removal and Installation

AIS001B7

SEC. 623

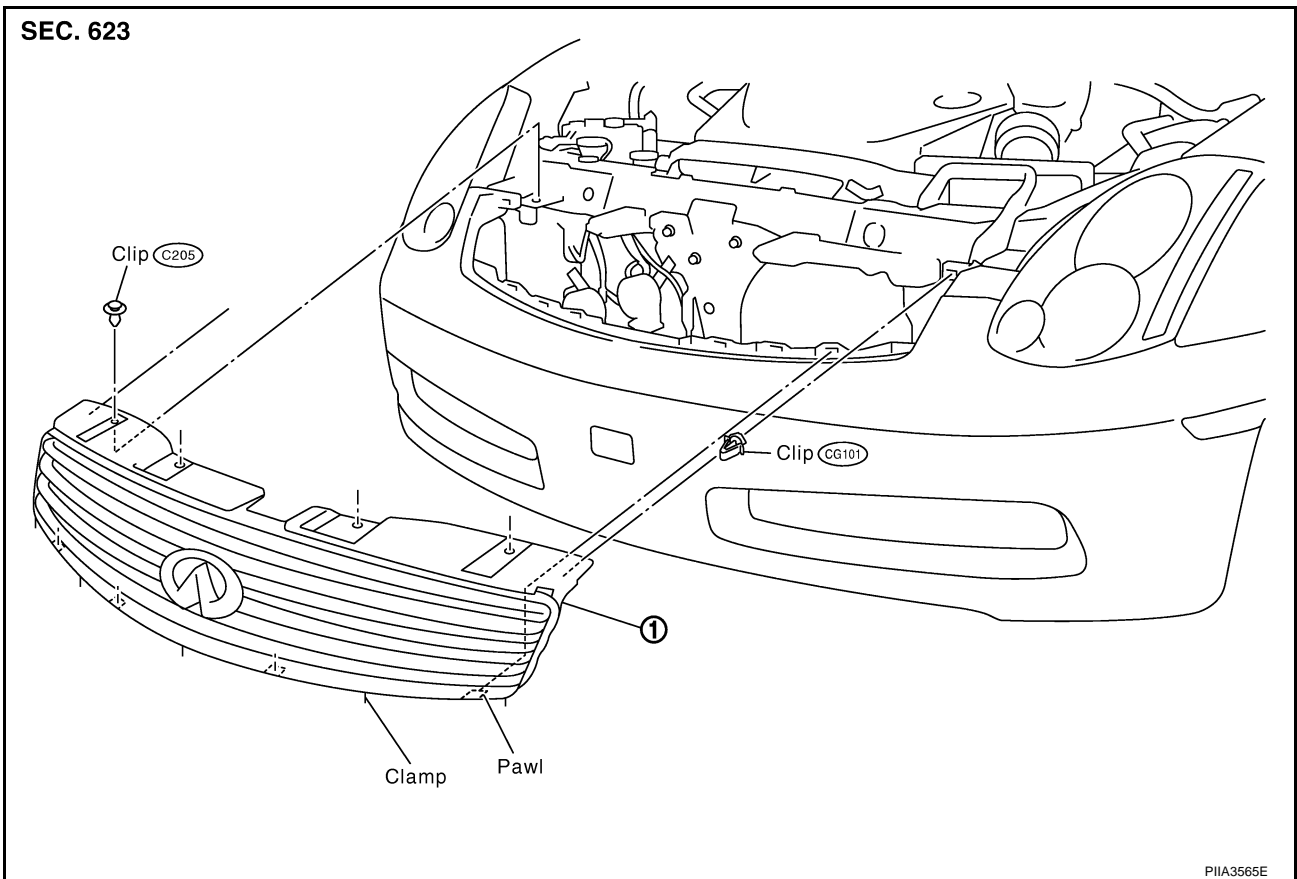

PIIA3565E

1. Front grille

### REMOVAL

1. Apply protection tape around outer circumference of front grille (bumper fascia side).
2. Remove clips on upper side of grille.
3. Pull down tips of four turn fasteners from rear side of grille.
4. Disconnect turn fasteners then pull out grille.

### INSTALLATION

Install in the reverse order of removal.

A  
B  
C  
D  
E  
F  
G  
H  
EI  
J  
K  
L  
M

# COWL TOP

## COWL TOP

PFP:66100

## Removal and Installation

AIS001B8

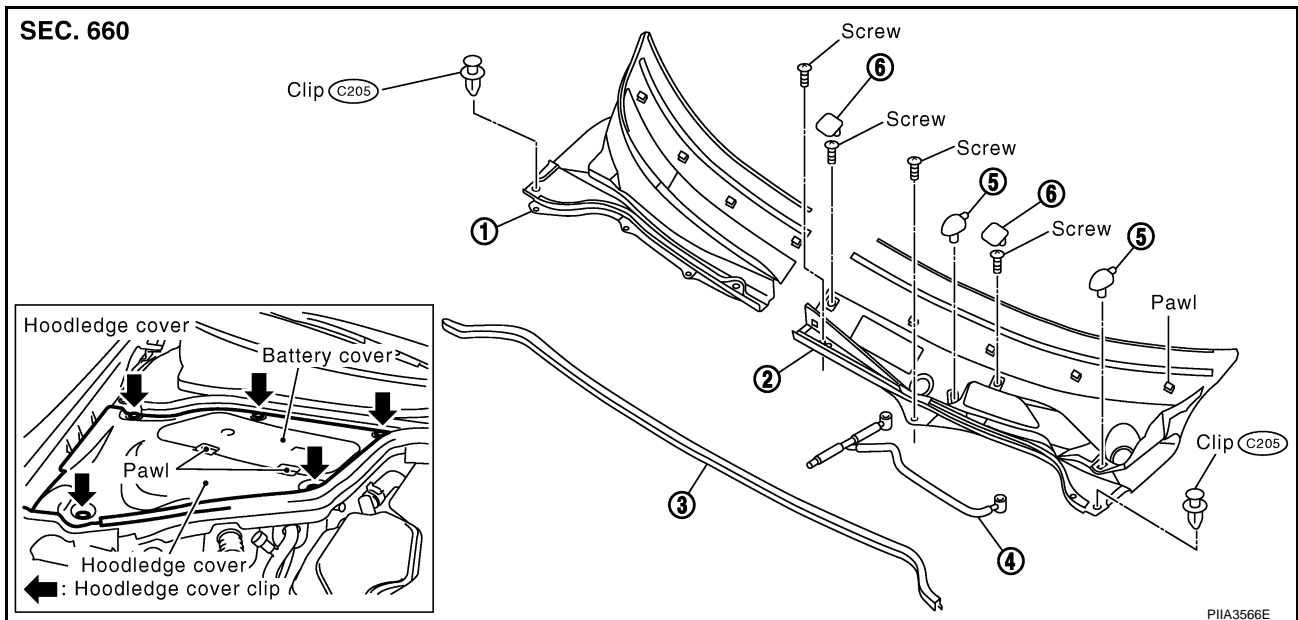

1. Cowl top cover (right)

2. Cowl top cover (left)

3. Cowl top seal rubber

4. Washer tube

5. Washer joint

6. Cap

### REMOVAL

1. Remove hood ledge cover.
2. Remove wiper arms of both side. Refer to [WW-30, "Removal and Installation of Front Wiper Arms, Adjustment of Wiper Arms Stop Location"](#) .
3. Remove cowl top seal rubber.
4. Remove clips of cowl top cover and remove cowl top cover (right).
5. Remove clips, caps, screws and remove cowl top cover (left).
6. Remove washer tube joint and hose from cowl top cover.

### INSTALLATION

Install in the reverse order of removal.

# FENDER PROTECTOR

## FENDER PROTECTOR Removal and Installation

PPF:63840

AIS004UD

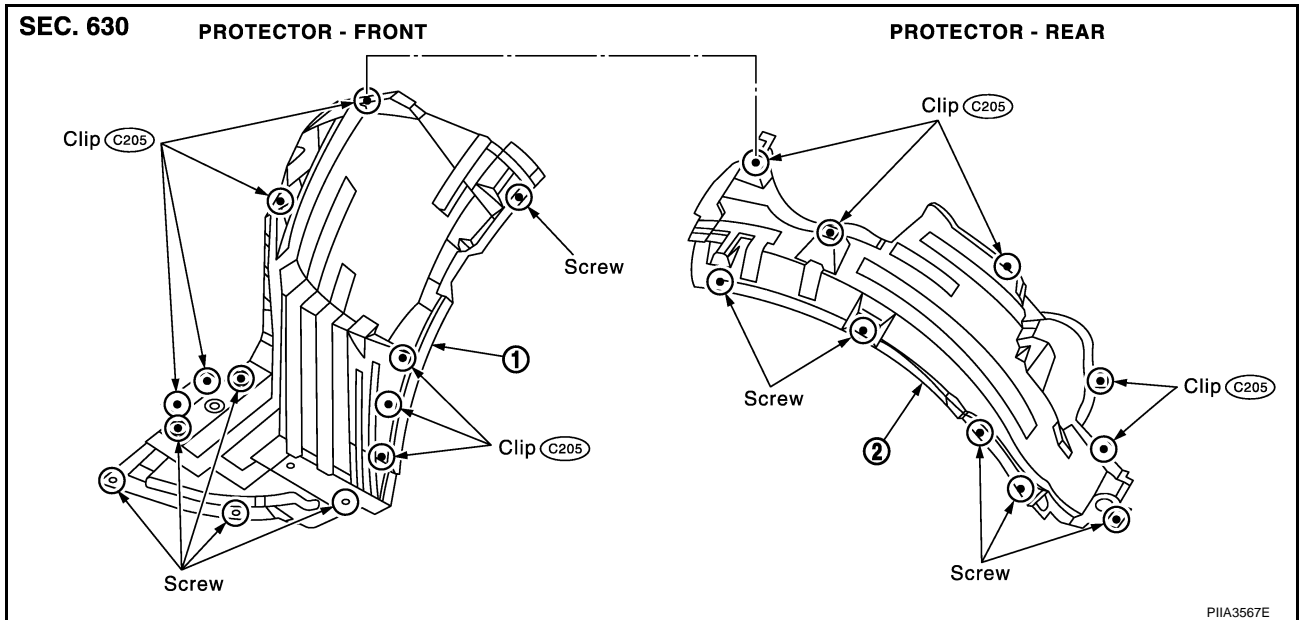

1. Fender protector (front)

2. Fender protector (rear)

### RE MOVAL

1. Remove screws and clips of fender protector.
2. Remove fender protector (front/rear).

### INSTALLATION

Install in the reverse order of removal.

A  
B  
C  
D  
E  
F  
G  
H  
EI  
J  
K  
L  
M

# DOOR OUTSIDE MOLDING

## DOOR OUTSIDE MOLDING

PFP:82820

### Removal and Installation

AIS001BA

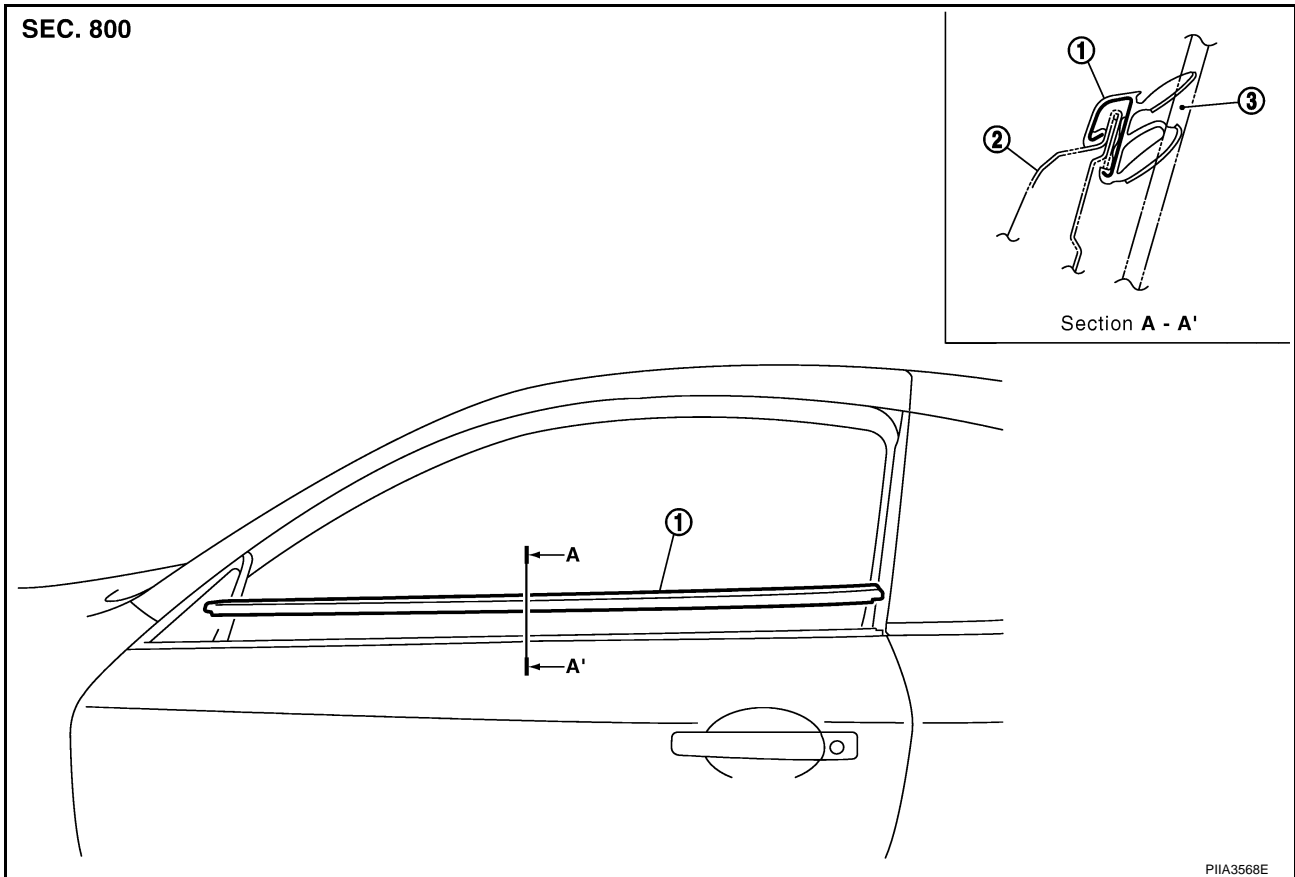

1. Door outside molding

2. Door panel (outer)

3. Door glass

### REMOVAL

1. Open windows fully.
2. Disconnect rear edge of molding.
3. Lift up molding to upper side and remove molding assembly.

### INSTALLATION

Install in the reverse order of removal.

# FRONT PILLAR FINISHER

## FRONT PILLAR FINISHER

PFP:76836

### Removal and Installation

AIS00271

A  
B  
C  
D  
E  
F  
G  
H  
EI  
J  
K  
L  
M

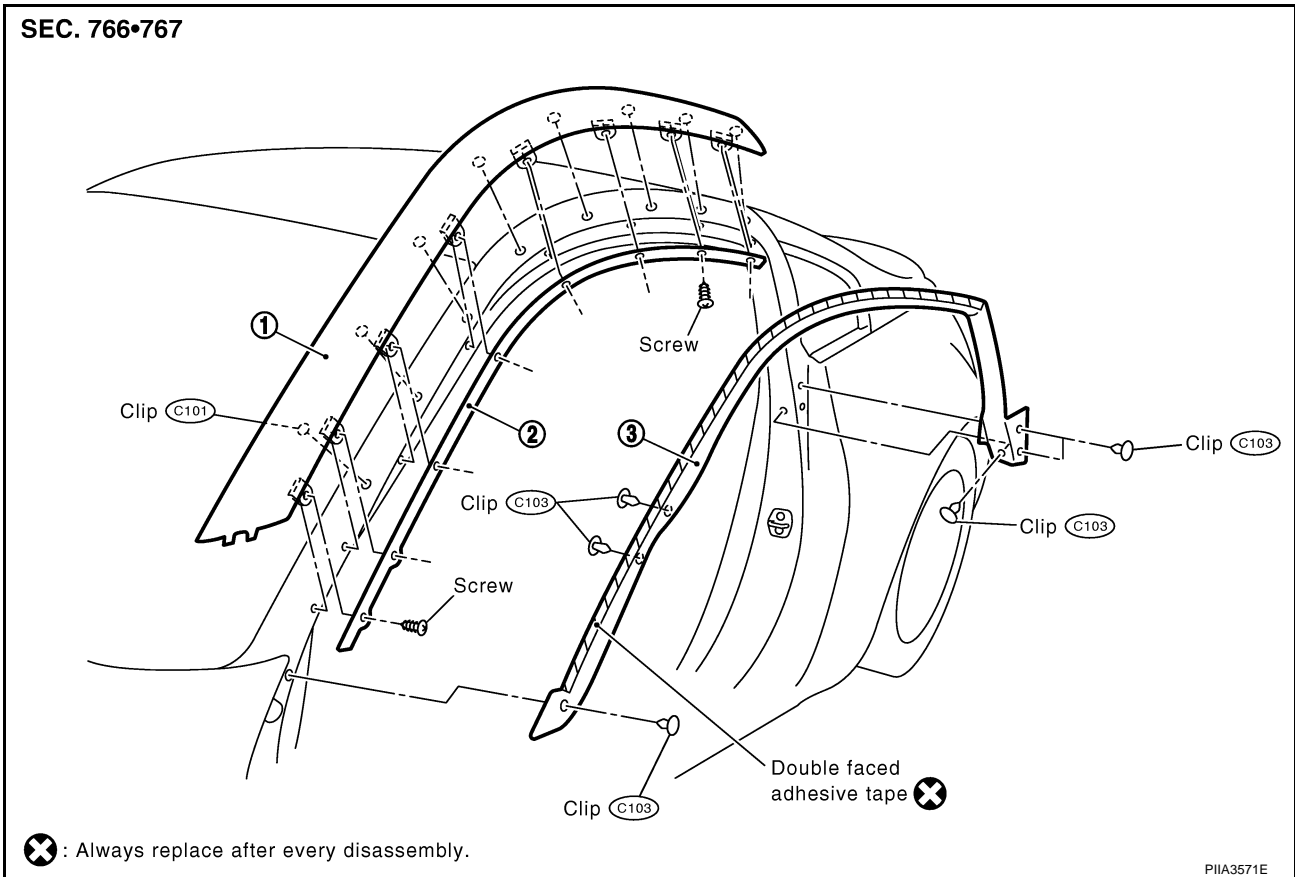

1. Front pillar finisher
2. Retainer body side weatherstrip
3. Body side weatherstrip

### REMOVAL

1. Remove clip and double-faced adhesive tapes of body side weatherstrip.
2. Remove body side weatherstrip.
3. Remove screw of retainer body side weatherstrip.
4. Remove screw and clip of front pillar finisher.
5. Remove front pillar finisher.

### INSTALLATION

Install in the reverse order of removal.

# CENTER MUD GUARD

## CENTER MUD GUARD

PFP:76850

### Removal and Installation

AIS001BE

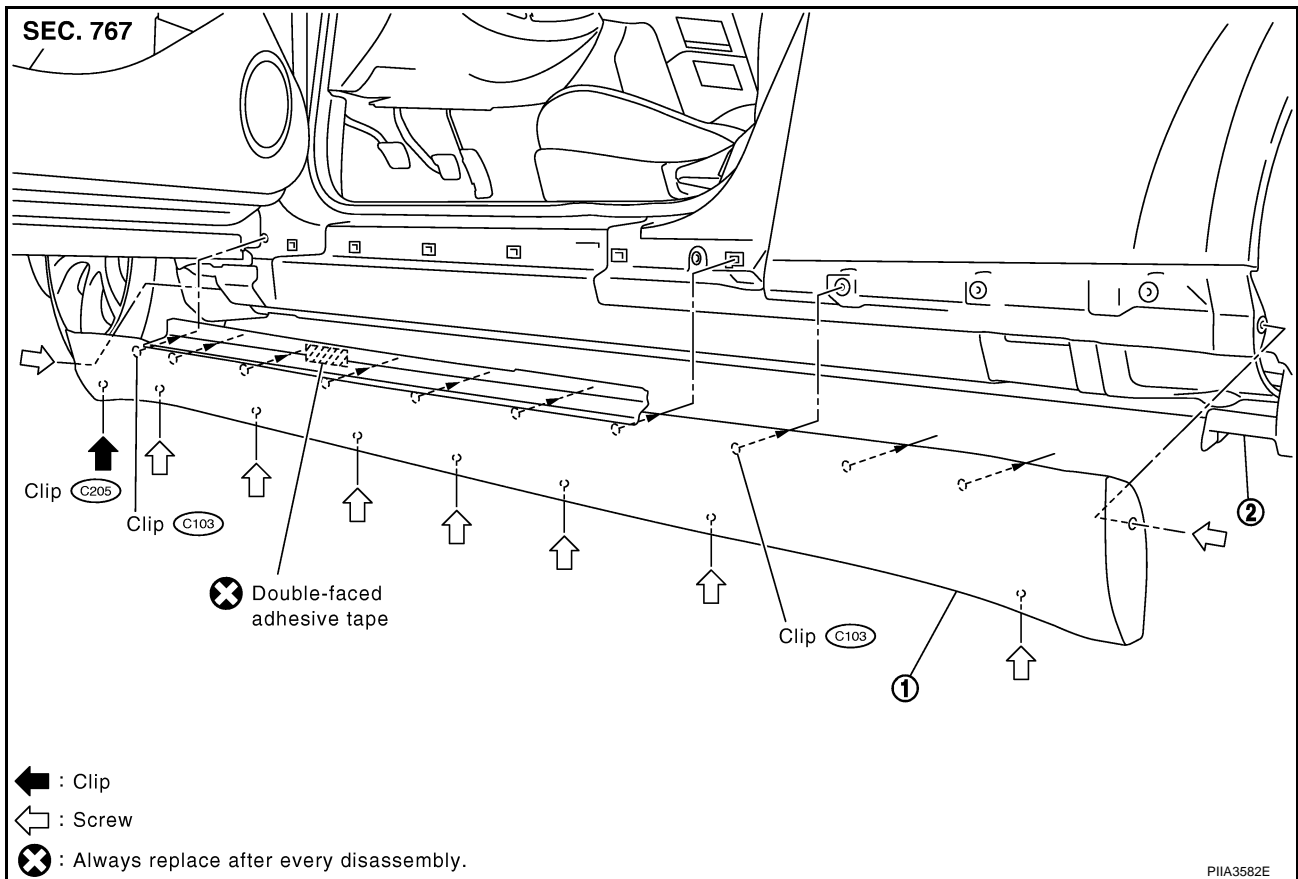

1. Center mud-guard

2. Center mud-guard rear

### REMOVAL

1. Remove center mud-guard finisher. Refer to [EI-32, "BODY SIDE TRIM"](#) .
2. Remove screws on front, rear and lower side of center mud-guard.
3. Disconnect clips on back side of center mud-guard.
4. Remove center mud-guard.

### INSTALLATION

Install in the reverse order of removal.



# WINDSHIELD MOLDING

PFP:72700

AIS001BG

## WINDSHIELD MOLDING

### Removal and Installation

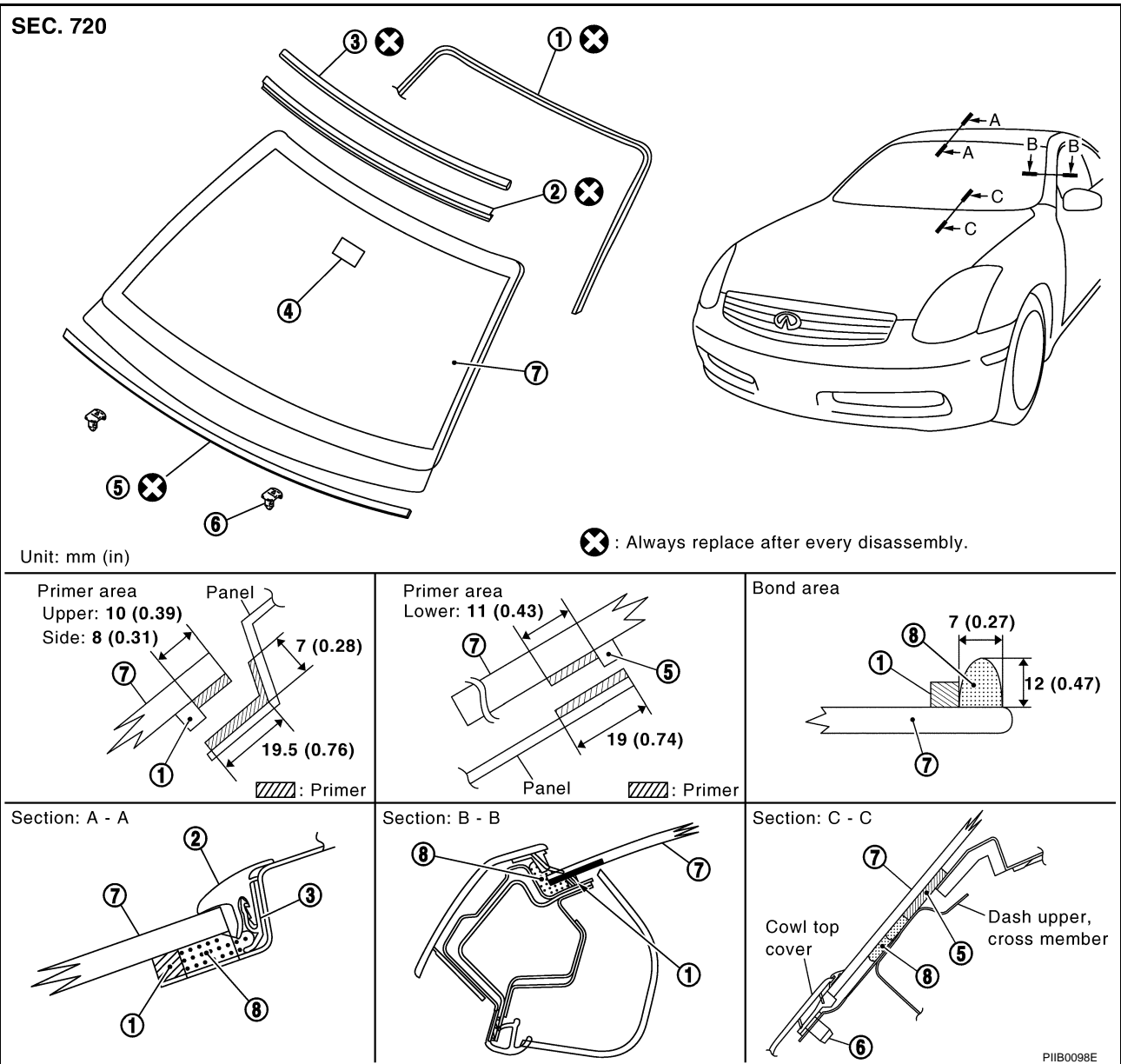

1. Dam rubber
4. Mirror base
7. Windshield glass

2. Molding (upper)
5. Insulator
8. Bond

3. Fastener
6. Spacer

### REMOVAL

Remove windshield molding. Refer to [GW-11, "WINDSHIELD GLASS"](#).

#### NOTE:

- Apply protective tape around circumference of windshield.
- Guiding a cutter knife along glass, cut surface of molding.
- Using pliers, draw out all remaining molding left in flanged area of body, and remove it completely from adhering surface on glass.

### INSTALLATION

Install windshield molding. Refer to [GW-11, "WINDSHIELD GLASS"](#).

#### NOTE:

- Align matching marks on body and glass. Install glass to body.

## WINDSHIELD MOLDING

---

- Press entire surface of glass lightly to fit it completely.

Using a spatula, repair any adhesive overflow or shortage to make surface smooth. Position windshield moldings and allow their adhesion.

**CAUTION:**

- **Be sure to install windshield molding before adhesive hardens.**
- **After installing glass, keep door windows open and avoid driving vehicle until adhesive has completely cured.**

# REAR WINDOW MOLDING

PFP:79762

AIS001BH

## REAR WINDOW MOLDING

### Removal and Installation

SEC. 797

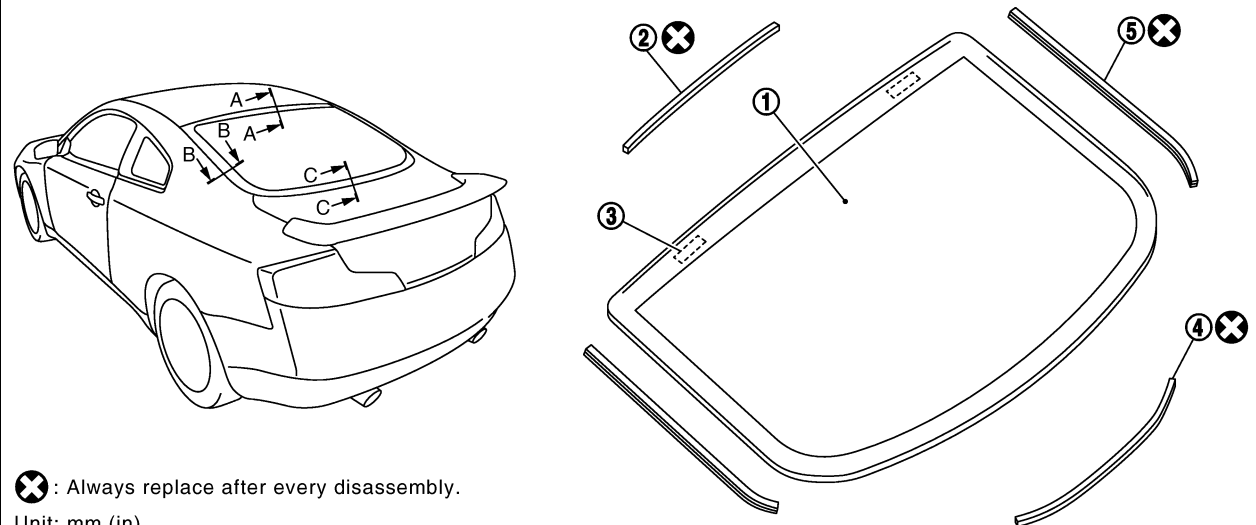

⊗ : Always replace after every disassembly.

Unit: mm (in)

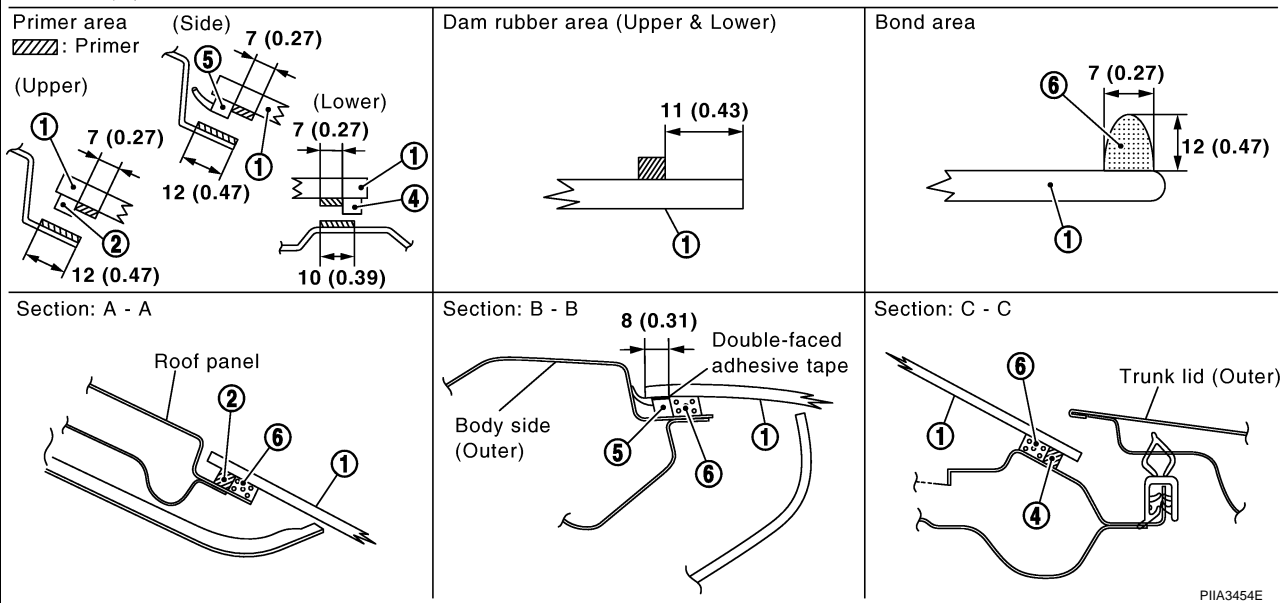

- |                       |                       |           |
|-----------------------|-----------------------|-----------|
| 1. Rear window glass  | 2. Dam rubber (upper) | 3. Spacer |
| 4. Dam rubber (lower) | 5. Molding (side)     | 6. Bond   |

### REMOVAL

Remove rear window molding. Refer to [GW-13, "REAR WINDOW GLASS AND MOLDING"](#) .

#### NOTE:

Apply a strip of protective tape along the contour of rear window glass (molding) to prevent paint surface from being damaged.

### INSTALLATION

Install rear window molding. Refer to [GW-13, "REAR WINDOW GLASS AND MOLDING"](#) .

#### NOTE:

- Clean adhesive portion of rear window glass and around circumference with white gasoline.
- Apply dam rubber to upper and lower surfaces of glass.
- Attach rear window molding to side face of glass.
- Rear window molding should not overlap on the surface of rear window glass.

A  
B  
C  
D  
E  
F  
G  
H  
EI  
J  
K  
L  
M

# REAR SPOILER

## REAR SPOILER

PFP:96030

### Removal and Installation

AIS001BK

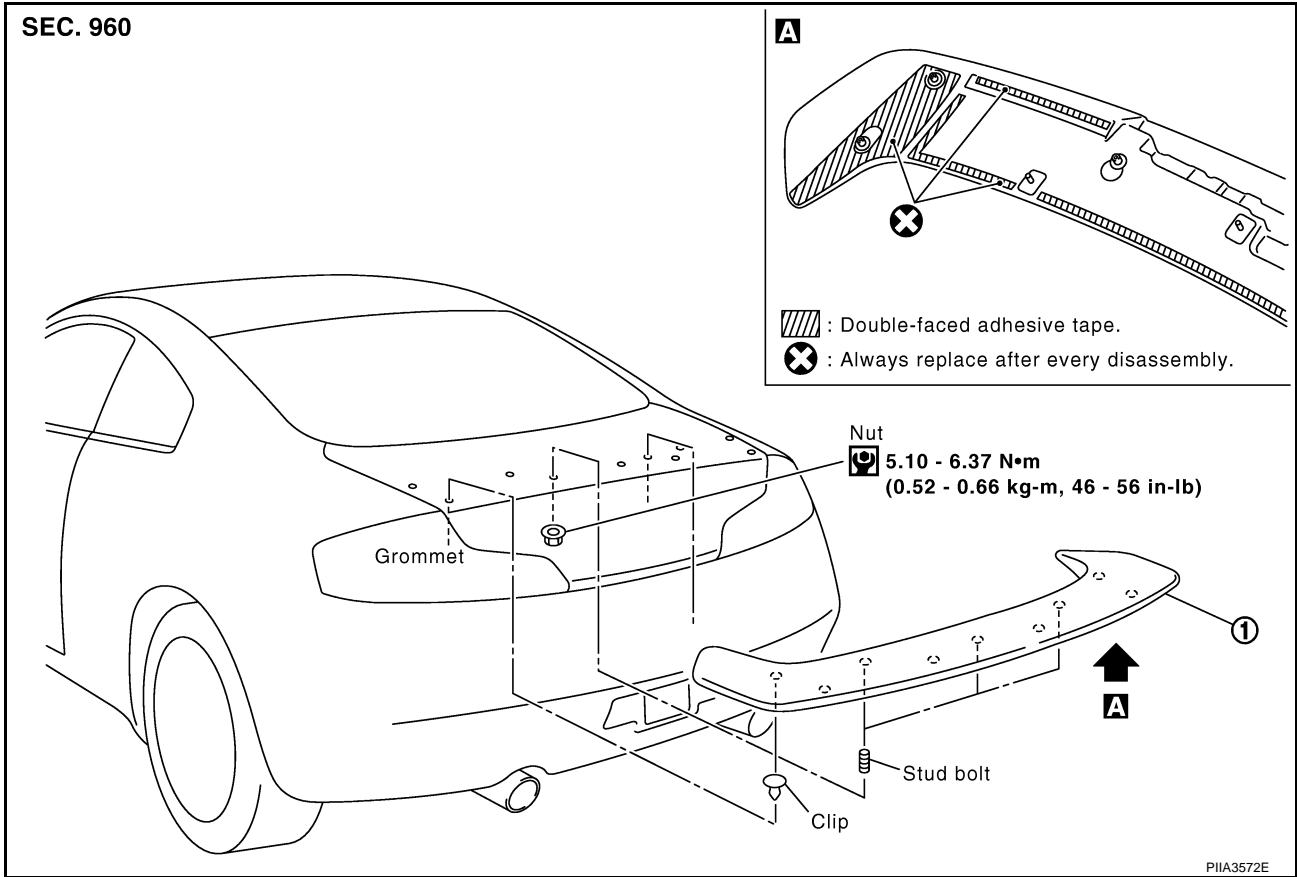

1. Rear spoiler

### REMOVAL

1. Remove trunk lid trim. Refer to [EI-40, "TRUNK ROOM TRIM & TRUNK LID FINISHER"](#).
2. Disconnect harness connector of high-mounted stop lamp.
3. Remove rear spoiler nuts.
4. Remove rear spoiler clip then disconnect grommet of high-mounted stop lamp harness.
5. Remove rear spoiler.

### INSTALLATION

Install in the reverse order of removal.

# ROOF SIDE MOLDING

## ROOF SIDE MOLDING

PFP:73854

### Removal and Installation

AIS001BL

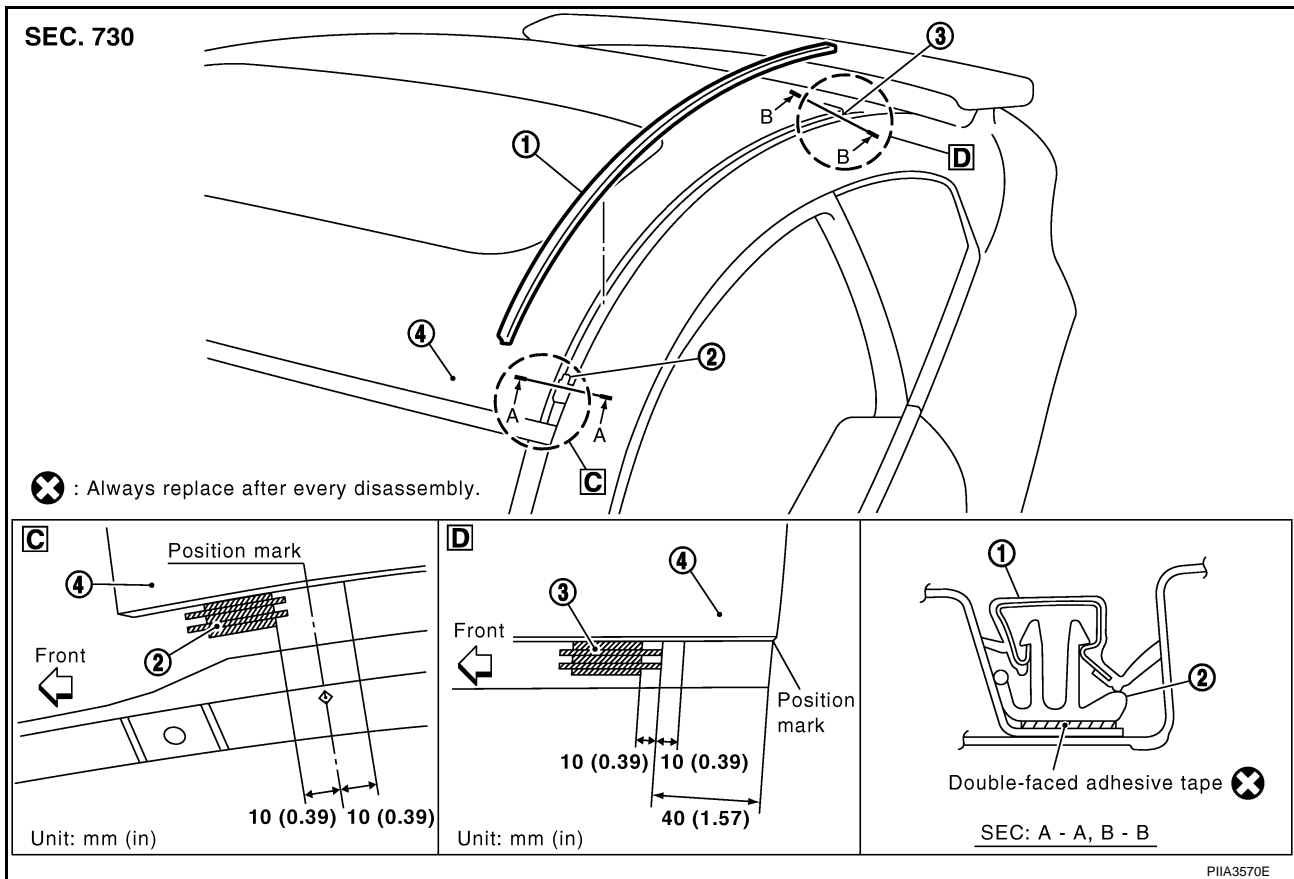

1. Roof side molding
4. Roof panel

2. Clip (front)

3. Clip (rear)

### REMOVAL

1. Remove molding front edge from body side clip.
2. Take off front edge of molding and remove rear end molding.
3. Remove front side clip and rear side clip.

### INSTALLATION

Install in the reverse order of removal paying attention to the following.

1. Apply double-faced adhesive tape and apply primer and adhesive on front edge of molding at standard extent (as indicated with [C] and [D] ).
2. When molding clip with damage after removing molding is found clip is exchange.

#### CAUTION:

**Be careful not to damage the body painting when you use the cutter and tool.**

# DOOR FINISHER

## DOOR FINISHER

PFP:80900

### Removal and Installation

AIS001BM

SEC. 809•828

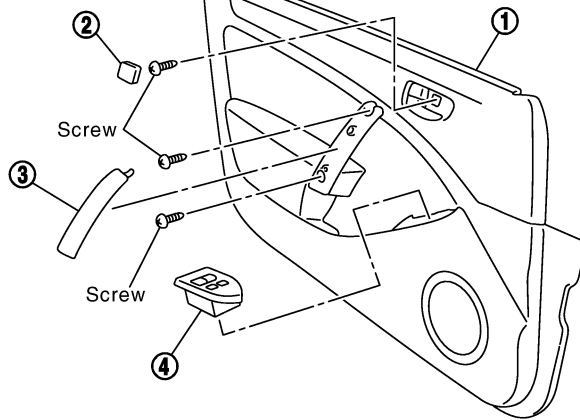

Door (Left)

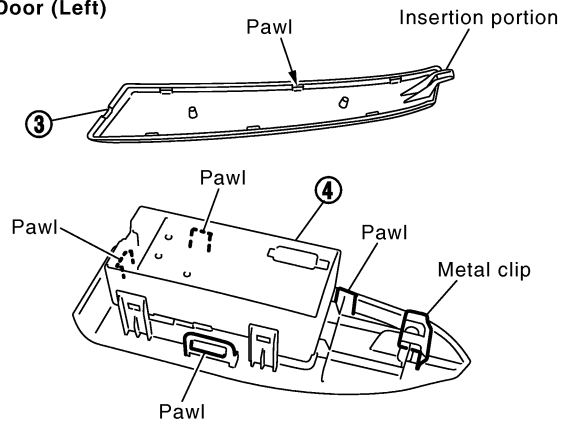

Door (Right)

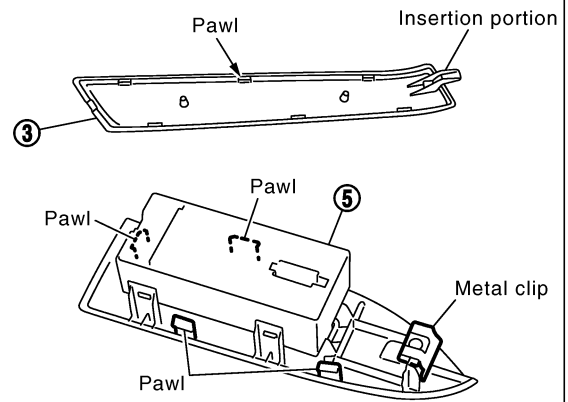

PIIA3573E

- |   |  |   |
|---|--|---|
| 1. Door finisher                        | 2. Mask (door)                           | 3. Door grip finisher (left / right door) |
| 4. Power window SW finisher (left door) | 5. Power window SW finisher (right door) |   |

### REMOVAL

1. Remove mask of inside handle portion and remove screws.
2. Insert taping flat-bladed screw driver into edge portion, disconnect pawls, and remove grip finisher.

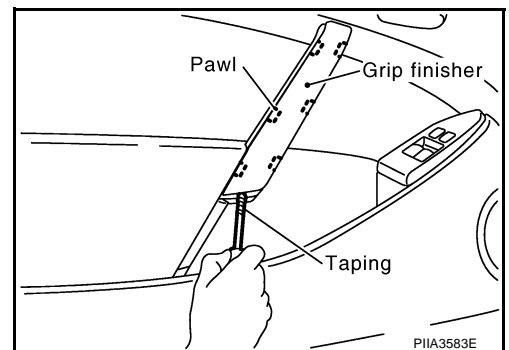

PIIA3583E

3. Remove screw of grip portion.

# DOOR FINISHER

4. Insert driver rolled with cloth between panel on vehicle and clips (as indicated with arrow), and remove finisher.

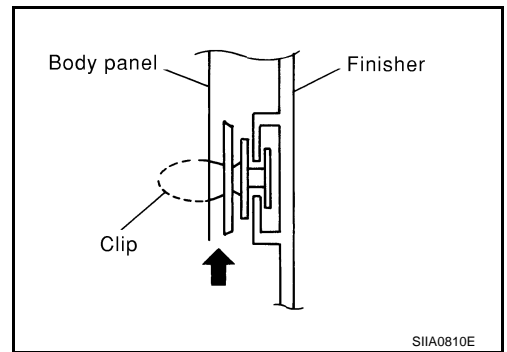

5. Pull up door finisher, and remove power window switch and electrical parts connectors.
6. Remove lock knob cable and inside handle cable of inside handle assembly back side.
7. Remove inside handle screws, and remove it from finisher.

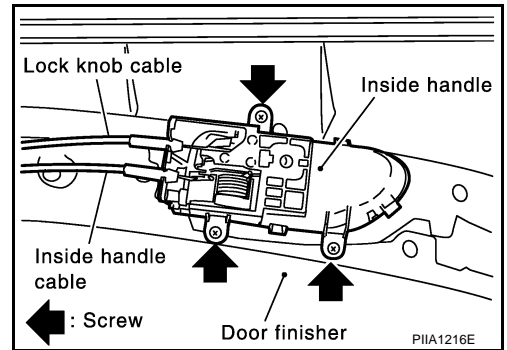

8. Disconnect metal clips and pawls from door finisher back side, and remove power window switch finisher.

## INSTALLATION

Install in the reverse order of removal.

### CAUTION:

To install finisher, check if all clips are matched over holes of panel on vehicle, then push it.

A  
B  
C  
D  
E  
F  
G  
H  
EI  
J  
K  
L  
M

# BODY SIDE TRIM

PFP:76913

AIS001BN

## BODY SIDE TRIM

### Removal and Installation

#### CAUTION:

Wrap the tip of flat-bladed screwdriver with a cloth when removing metal clips from garnishes.

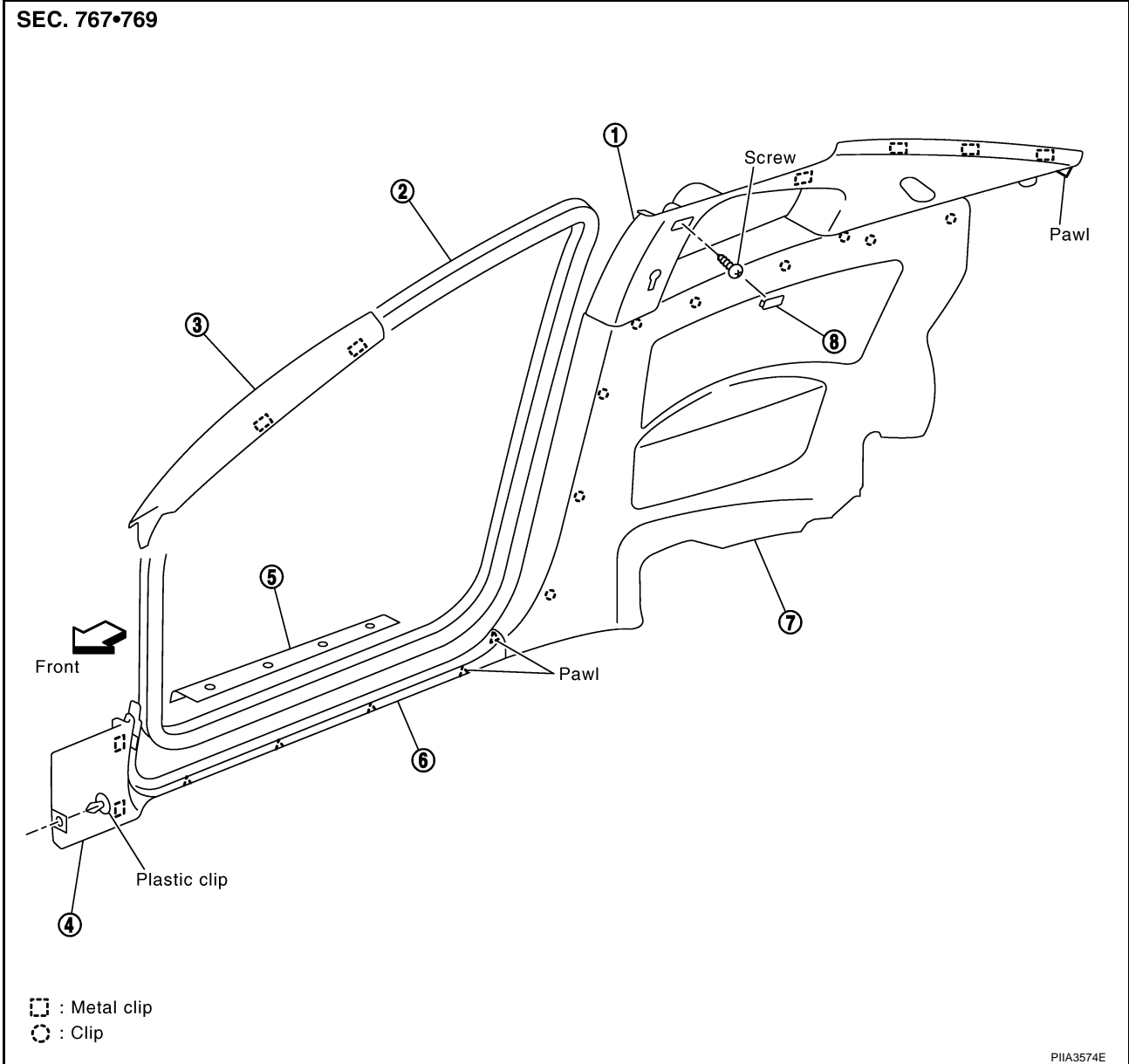

- |                        |                              |                         |
|------------------------|------------------------------|-------------------------|
| 1. Rear pillar garnish | 2. Body side welt            | 3. Front pillar garnish |
| 4. Dash side finisher  | 5. Center mud guard finisher | 6. Kicking plate        |
| 7. Rear side finisher  | 8. Cap                       |                         |

### REAR SIDE FINISHER

#### Removal

1. Remove kicking plate.
2. Remove body side welt.
3. Remove rear side finisher.

#### Installation

Install in the reverse order of removal.



# BODY SIDE TRIM

## REAR PILLAR GARNISH

### Removal

1. Remove rear seat cushion. Refer to [SE-60, "REAR SEAT"](#) .
2. Remove front seat belt shoulder anchor bolts. Refer to [SB-4, "Removal and Installation of Front Seat Belt"](#) .
3. Remove rear seat belt floor anchor bolts. Refer to [SB-6, "Removal and Installation of Rear Seat Belt"](#) .
4. Remove kicking plate.
5. Remove body side welt.
6. Remove rear side finisher.
7. Remove rear pillar garnish.

### Installation

Install in the reverse order of removal.

## FRONT PILLAR GARNISH

### Removal

1. Remove kicking plate.
2. Remove body side welt.
3. Remove front pillar garnish.

### Installation

Install in the reverse order of removal.

## KICKING PLATE

### Removal

Remove kicking plate.

### Installation

Install in the reverse order of removal.

## CENTER MUD GUARD FINISHER

### Removal

Remove center mud guard finisher.

### Installation

Install in the reverse order of removal.

## DASH SIDE FINISHER

### Removal

1. Remove kicking plate.
2. Remove body side welt.
3. Remove dash side finisher.

### NOTE:

Insert screw driver rolled with cloth between panel on vehicle and clips (as indicated with arrow), and disconnect clips.

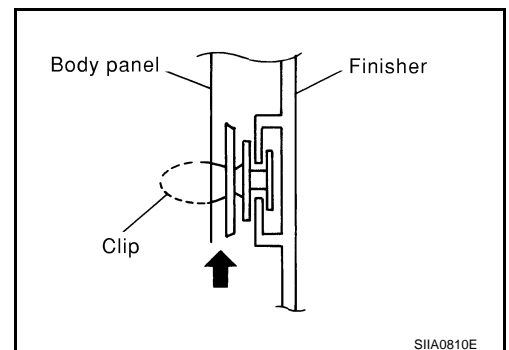

### Installation

Install in the reverse order of removal.

## BODY SIDE TRIM

---

**NOTE:**

To install, check if all clips are matched over holes of panel on vehicle, then push on.

# REAR PARCEL SHELF FINISHER

## REAR PARCEL SHELF FINISHER

PPF:79910

### Removal and Installation

AIS001B0

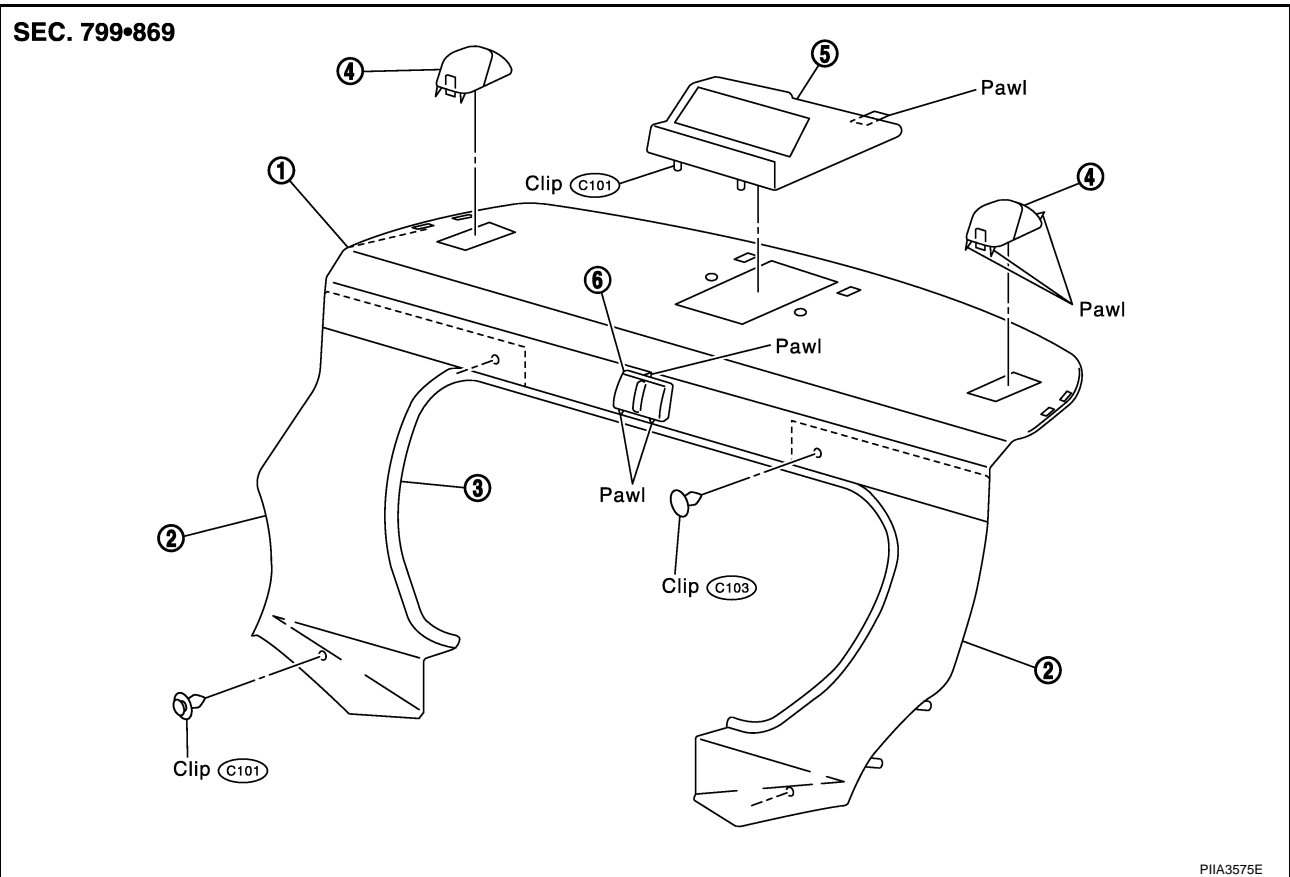

- |                               |                           |                                 |
|-------------------------------|---------------------------|---------------------------------|
| 1. Rear parcel shelf finisher | 2. Rear seat back trim    | 3. Rear seat back welt          |
| 4. Child anchor cover         | 5. High-mounted stop lamp | 6. Rear seat back striker cover |

### REMOVAL

1. Remove rear seat. Refer to [SE-60, "REAR SEAT"](#) .
2. Remove kicking plate. Refer to [EI-32, "BODY SIDE TRIM"](#) .
3. Remove body side welt. Refer to [EI-32, "BODY SIDE TRIM"](#) .
4. Remove front seat belt floor shoulder anchor bolts. Refer to [SB-4, "SEAT BELTS"](#) .
5. Remove rear seat belt floor anchor bolts. Refer to [SB-6, "Removal and Installation of Rear Seat Belt"](#) .
6. Remove rear side finisher. Refer to [EI-32, "BODY SIDE TRIM"](#) .
7. Remove rear pillar garnish. Refer to [EI-32, "BODY SIDE TRIM"](#) .
8. Remove rear seatback striker cover.
9. Remove clips of rear parcel shelf finisher.
10. Remove child anchor cover .
11. Remove high-mounted stop lamp and electrical parts connector.
12. Remove rear parcel shelf finisher.

### INSTALLATION

Install in the reverse order of removal.

#### CAUTION:

- Confirm hooks of rear parcel shelf finisher are completely inserted into holes on vehicle side.
- Confirm clips are matched over holes on vehicle side, then push on.

# FLOOR TRIM

## FLOOR TRIM

PFP:74902

### Removal and Installation

AIS001BP

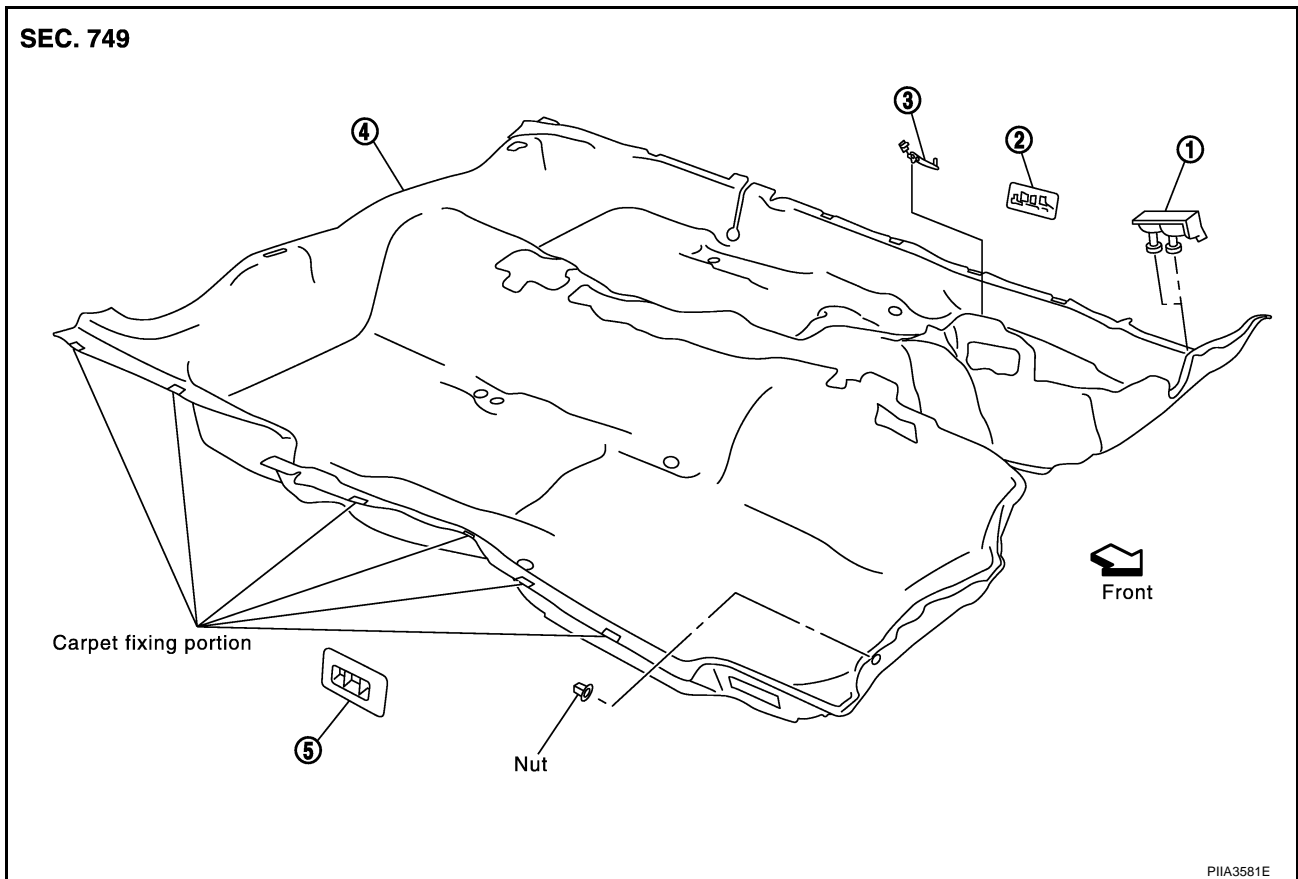

1. Foot-rest (driver)

2. Foot-grille (left)

3. Carpet hook

4. Floor carpet

5. Foot-grille (right)

### REMOVAL

1. The battery terminal is removed and waits for three minutes.
2. Remove front seat and rear seat cushion. Refer to [SE-55, "Removal and Installation"](#) and [SE-60, "Removal and Installation"](#).
3. Remove instrument side panel (left and right). Refer to [IP-10, "INSTRUMENT PANEL ASSEMBLY"](#).
4. Remove center console. Refer to [IP-10, "INSTRUMENT PANEL ASSEMBLY"](#).
5. Remove kicking plate. Refer to [EI-32, "BODY SIDE TRIM"](#).
6. Remove body side welt. Refer to [EI-32, "BODY SIDE TRIM"](#).
7. Remove rear side finisher. Refer to [EI-32, "BODY SIDE TRIM"](#).
8. Remove dash side finisher. Refer to [EI-32, "BODY SIDE TRIM"](#).
9. Turn flat-bladed screw driver in counter-clockwise, and remove foot-rest from stud bolts on vehicle.
10. Remove foot-rest.
11. Remove front seat belt floor anchor bolts. Refer to [SB-4, "SEAT BELTS"](#).
12. Remove air bag cpu assembly bracket. Refer to [SRS-50, "DIAGNOSIS SENSOR UNIT"](#).

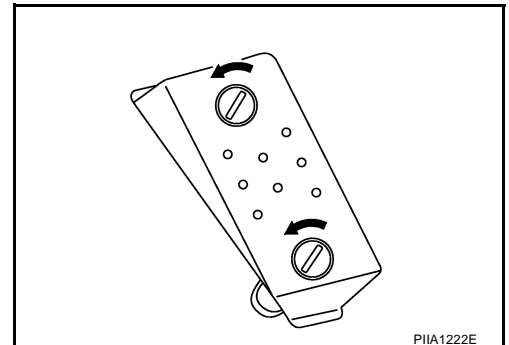

# FLOOR TRIM

13. Remove carpet hook.

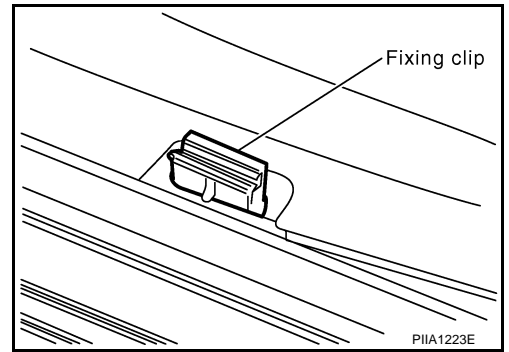

14. Remove floor carpet from carpet clip and remove floor carpet.

## INSTALLATION

Install in the reverse order of removal.

A  
B  
C  
D  
E  
F  
G  
H  
EI  
J  
K  
L  
M

# HEADLINING

PFP:73910

## HEADLINING

### Removal and Installation

AIS001BQ

SEC. 264•738•964

Without sunroof

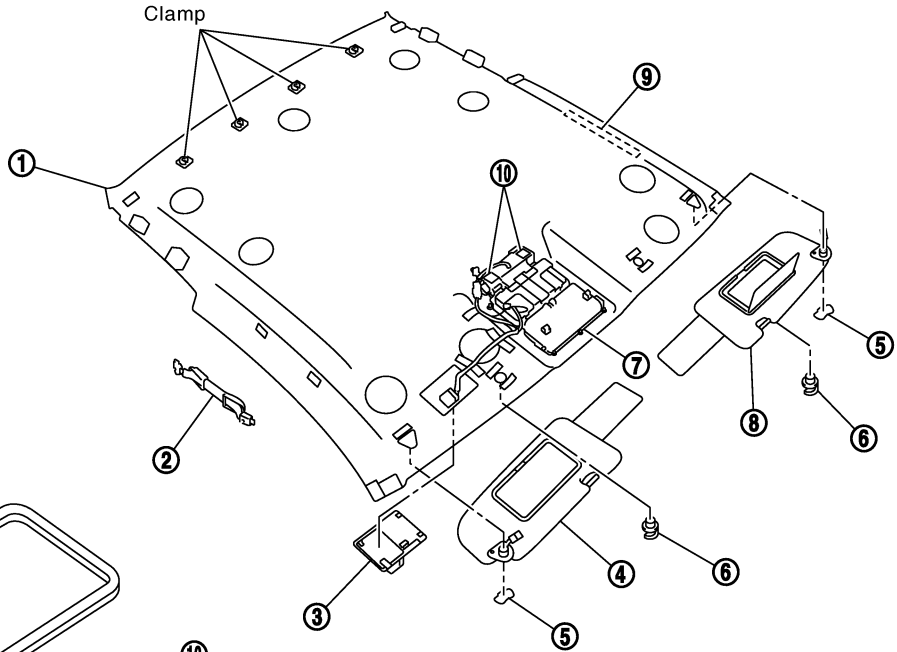

With sunroof

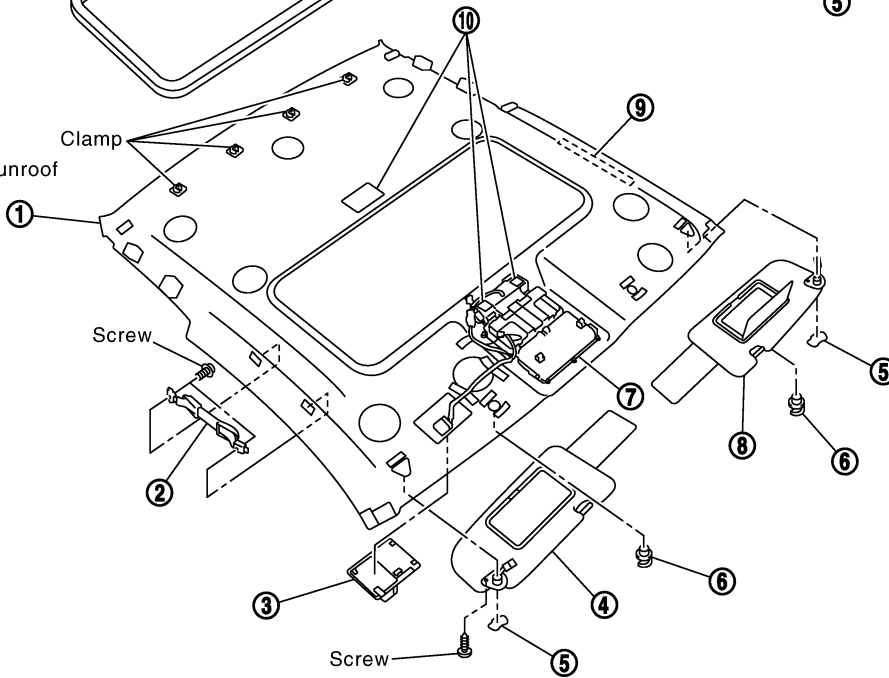

PIIA3576E

- |                        |                     |                        |
|------------------------|---------------------|------------------------|
| 1. Headlining          | 2. Assist grip      | 3. Roof front finisher |
| 4. Sun-visor (right)   | 5. Sun-visor cover  | 6. Sun-visor holder    |
| 7. Spot lamp           | 8. Sun-visor (left) | 9. Card holder         |
| 10. Dual lock fastener | 11. Sunroof welt    |                        |

# HEADLINING

## REMOVAL

1. Remove front pillar garnish. Refer to [EI-32, "BODY SIDE TRIM"](#) .
2. Remove rear side finisher. Refer to [EI-32, "BODY SIDE TRIM"](#) .
3. Remove rear pillar garnish. Refer to [EI-32, "BODY SIDE TRIM"](#) .
4. Remove assist grip cover, disconnect pawls both on upper and lower parts insert clip clamp remover, slide cover inward, and remove screws.

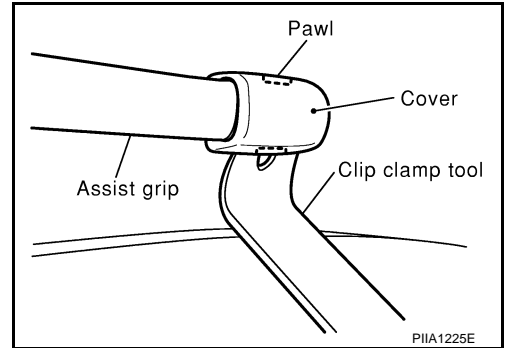

5. Remove sun-visor (drive and passenger), and disconnect harness connector with lamp model.
6. Remove sun-visors holder.

### NOTE:

Insert flat-bladed screw driver to edge, and turn it 90 degrees and remove sun-visor holder.

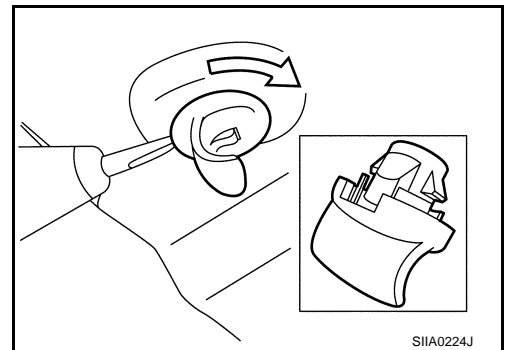

7. Remove spot lamp.
8. Remove roof front finisher and remove headlining module harness connector.
9. Remove sunroof welt (with sunroof only).
10. Remove dual lock fastener.
11. Put front seat to front most and recline seatback to backward.
12. Remove headlining, turn and take out from right side door.

### CAUTION:

- Always remove or install in a pair.
- Cover surroundings with waste to avoid scratches or damages.
- Do not bend headlining too hard.

## INSTALLATION

Install in the reverse order of removal.

# TRUNK ROOM TRIM & TRUNK LID FINISHER

## TRUNK ROOM TRIM & TRUNK LID FINISHER

PFP:84920

### Removal and Installation for Trunk Room Trim

AIS001BR

SEC. 849

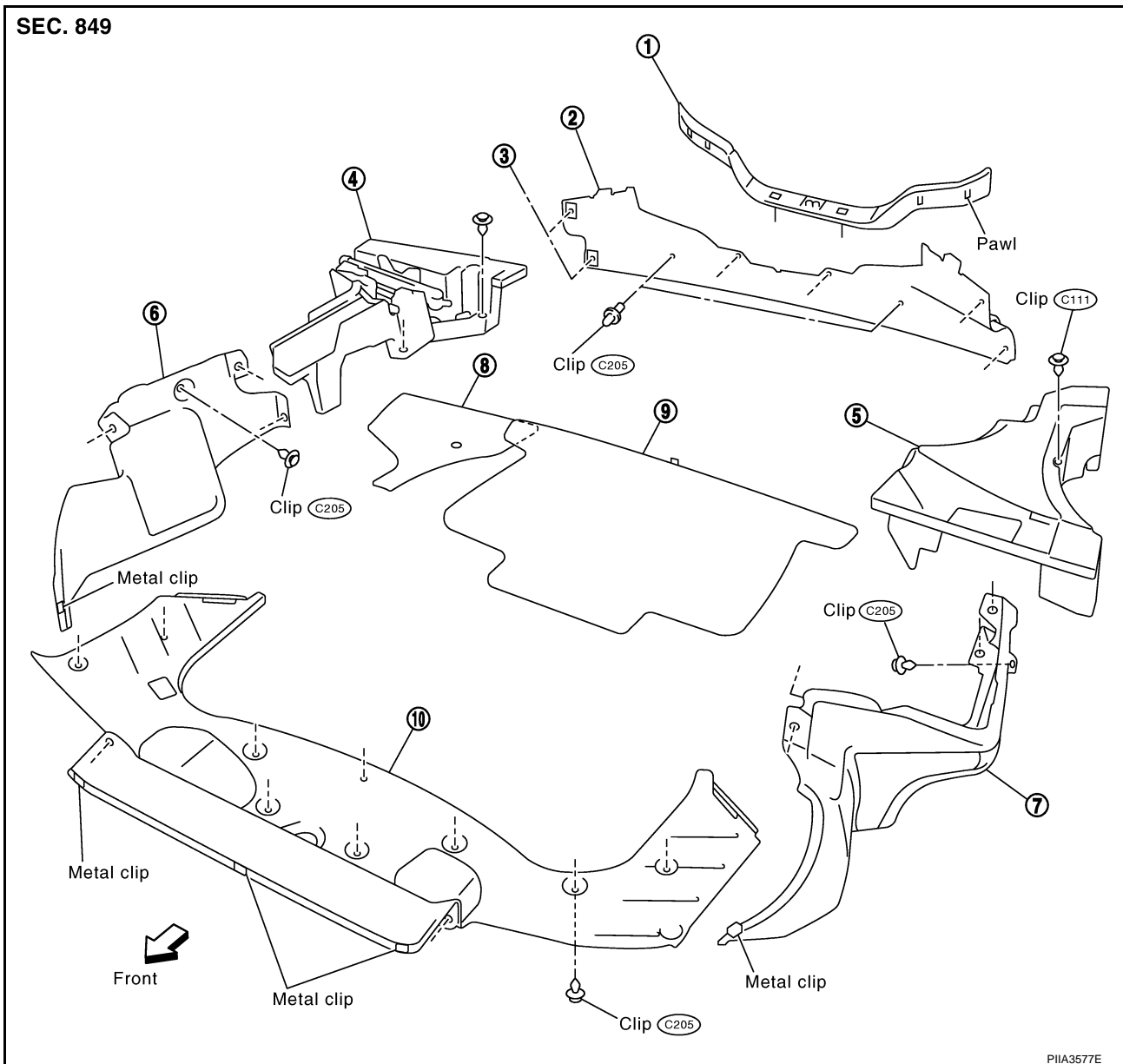

- |                                    |                              |                                     |
|------------------------------------|------------------------------|-------------------------------------|
| 1. Trunk rear plate                | 2. Trunk Rear finisher (end) | 3. Net hook                         |
| 4. Trunk floor spacer (right)      | 5. Trunk floor spacer (left) | 6. Rear wheelhouse finisher (right) |
| 7. Rear wheelhouse finisher (left) | 8. Trunk floor board (right) | 9. Trunk floor board (center)       |
| 10. Trunk rear finisher (upper)    |                              |                                     |

### TRUNK ROOM TRIM

#### Removal

1. Remove trunk floor board.
2. Remove trunk rear plate.
3. Remove trunk rear finisher (end).
4. Remove trunk rear finisher welt.
5. Remove rear seat back lever finisher.
6. Remove trunk rear finisher (upper).
7. Remove rear wheelhouse finisher (left/right).



# TRUNK ROOM TRIM & TRUNK LID FINISHER

## Installation

Install in the reverse order of removal.

## TRUNK LID FINISHER

### Removal

1. Remove clips of trunk lid finisher.
2. Remove trunk lid emergency handle.
3. Remove trunk lid finisher.

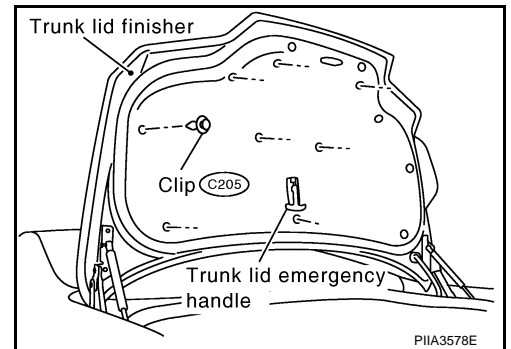

## Installation

Install in the reverse order of removal.

A  
B  
C  
D  
E  
F  
G  
H  
EI  
J  
K  
L  
M

# TRUNK ROOM TRIM & TRUNK LID FINISHER

---